

ACREASE

60" FINISH CUT



C60K



H60T



H60H



E60B

OWNER'S MANUAL

With Assembly Instructions

For Models: C60K, H60T, H60H & E60B

KUNZ ENGINEERING, INC. / MENDOTA, IL 61342 / PH (815) 539-6954



ASSEMBLY INSTRUCTIONS

READ THE COMPLETE ASSEMBLY INSTRUCTIONS BEFORE STARTING THE ASSEMBLY.

You should have:

- one mower deck assembly
- two caster assemblies
- two rear axle assemblies
- one tongue assembly (Lawn & Garden Hitching or ATV Tongue)
- one tow vehicle hitch assembly (only included on Lawn & Garden Hitching)

Optional hitches:

- one tongue extension
- one rear hitch assembly

A. ASSEMBLY OF MOWER WHEELS

1. Set the mower deck assembly on wood blocks so that it is suspended off the ground.

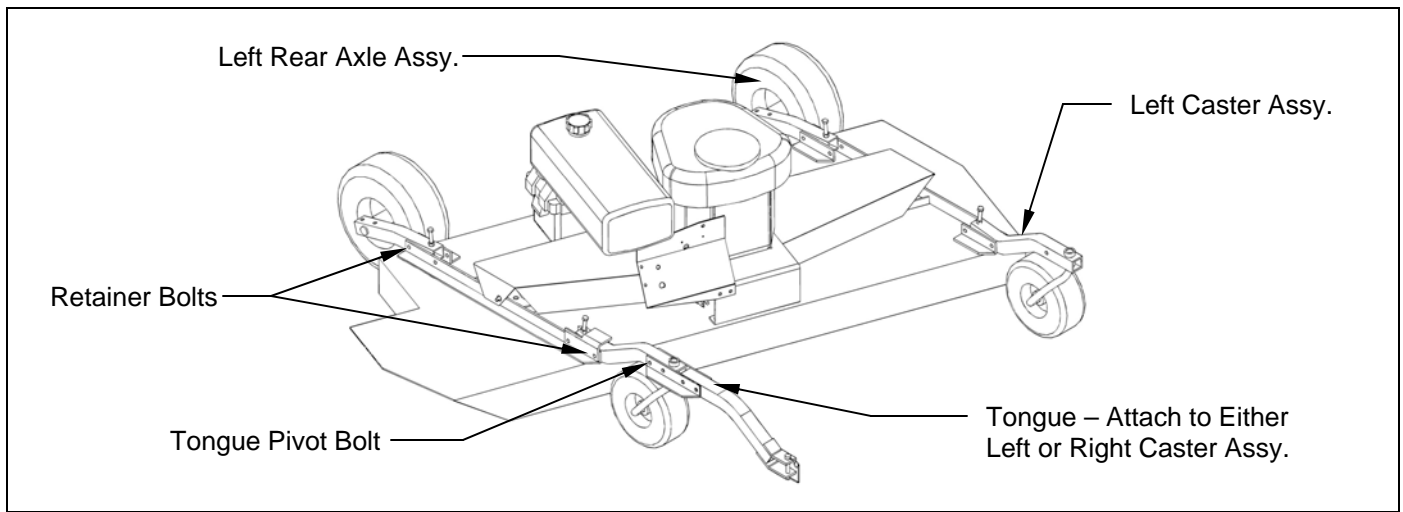

Figure 1. Assembly of Wheels, Tongue and Rear Hitch

2. Install the two caster assemblies in the retainers on the front of the mower deck. **See figure 1.** Before securing the caster supports, determine which side of the mower the tongue will be placed on and install the caster support stop on the tongue side. **See Figure 2.** Secure with 3/8" x 2-3/4" hex head bolt, lock washer, and nut provided in the retainer areas.

Note: The operator controls are on the front of the deck and the discharge chute is on the right side. (Left and right are determined from looking in the direction of travel.)

3. Install the two rear axle assemblies in the retainers on the rear of the mower deck. The tire should be to the left of the axle support. **See figure 1.** Secure with 3/8" x 2-1/2" hex head bolt, lock washer, and nut provided in the retainer areas.

Note: Tighten the four wheel assembly pivot bolts so that the wheel assemblies will not flop down when the deck is raised off the ground.

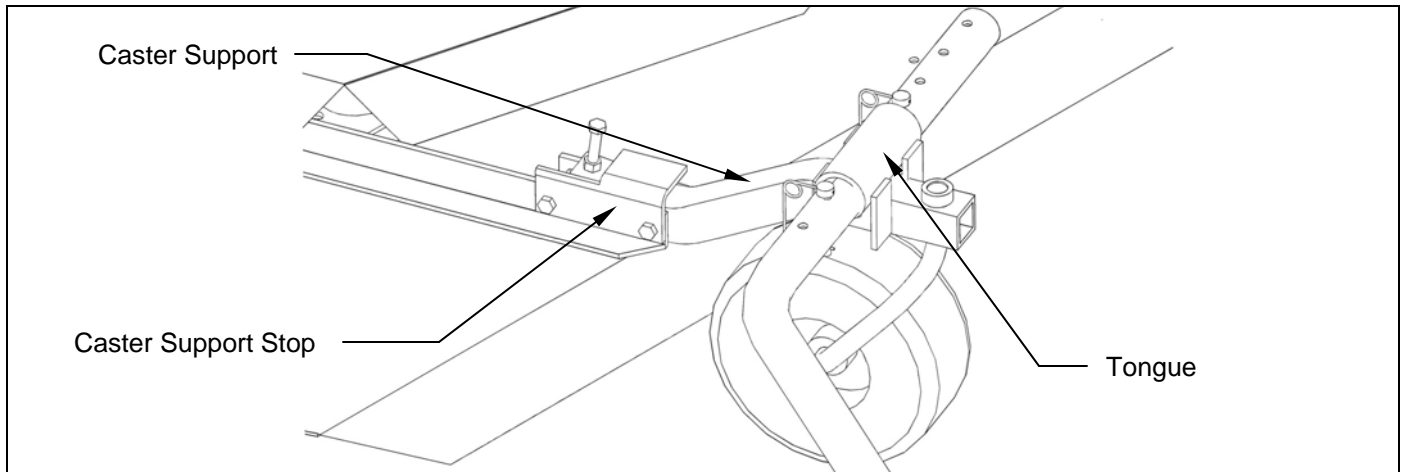

Figure 2: Installation of Caster Support Stop

B. INSTALLATION OF LAWN & GARDEN HITCHING (refer to the Operation and Adjustment Section for recommended hitching)(if the ATV Tongue was purchased refer to section C. Installation of ATV Tongue)

1. The tongue can be installed either on the left or right caster assembly depending on how the wing mower will be towed. **See figure 1.** Tighten the lock nut on the 3/8" x 2-1/2" pivot bolt so the tongue is free to pivot but does not move sideways.

Note: The tongue can be installed upside down so it will match up with tow vehicles with higher hitches.

2. The tow vehicle hitch provided is a universal hitch that should fit most tow vehicles. Slight modifications may be necessary for some tow vehicles.
3. Attach the tow vehicle hitch to the tow vehicle draw bar top or bottom depending on best support, and secure with the longer 1/2" hex head bolt, flatwasher, nut, and lockwasher provided. **See figure 3.**

Note: On some tow vehicles the draw bar will need to be strengthened to support the hitch assembly securely.

4. Adjust the hitch stop angle with stop bolts as close as possible to the vertical member on the back of the tow vehicle and adjust stop bolts securely against vertical member to keep hitch from pivoting from side to side.

Note: The hitch should be positioned on the tow vehicle so the stop bolts have a solid member to adjust to. On most tow vehicles two bolts can be used to attach the hitch assembly to the draw bar, eliminating the need for the hitch stop angle.

5. The telescoping hitch can either be installed to the left or right and should clear the back of the tire by about 2".
6. If one mower is pulled on both the left and right side of the tow vehicle, then one telescoping hitch can be mounted to the left and one to the right.

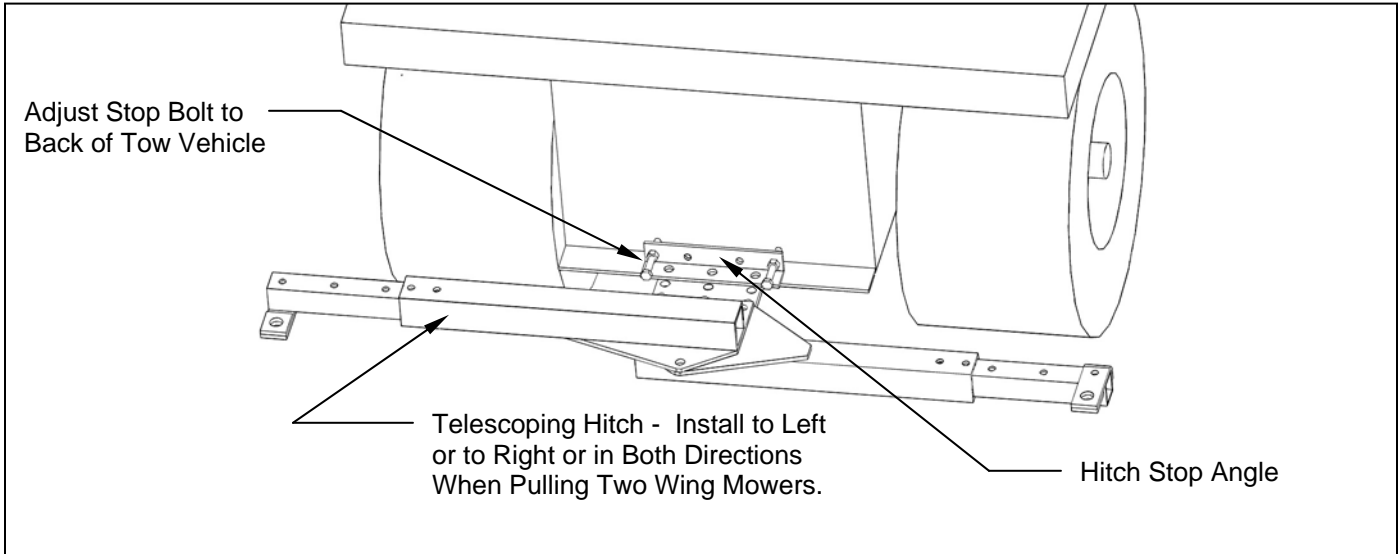

Figure 3: Installation of Tow Vehicle Hitch

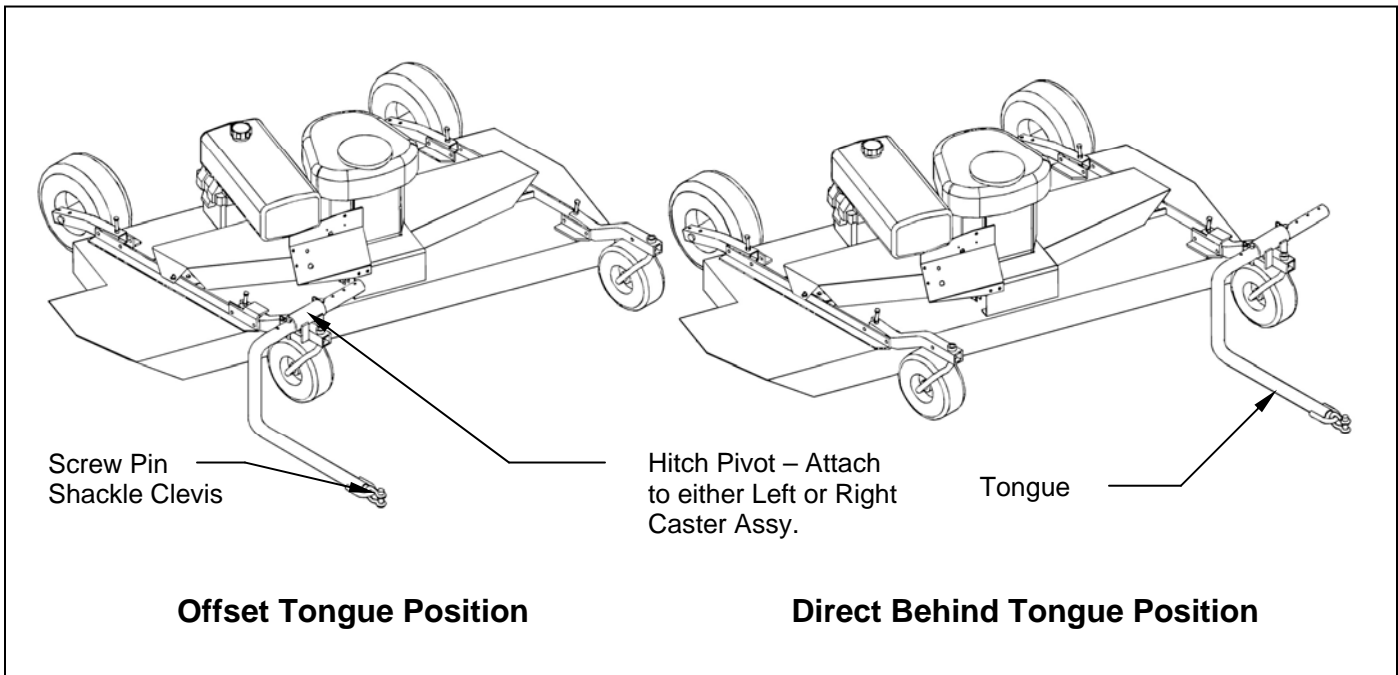

Figure 4. Assembly of Hitch Pivot and Tongue

C. INSTALLATION OF ATV TONGUE ASSEMBLY (if the lawn and garden hitching was purchased refer to Section B. Installation of Lawn & Garden Hitching)

1. The tongue can be installed either on the left or right caster assembly depending on how the wing mower will be towed. **See figure 4.** Secure the hitch pivot on the chosen caster assembly with the 3/8" x 2-1/2" hex head bolt, lock washer, and nut provided.
2. Install the tongue into the hitch pivot and secure by placing a 5/16" wire lock pin on each side of the hitch pivot.

D. INSTALLATION OF OPTIONAL HITCHES

1. When a long tongue is needed, remove the tongue pivot angles and spacer from the tongue assembly and attach to the tongue extension. **See figure 5.** Slip the tongue in between the two flats on the tongue extension and secure with 3/8" x 2-1/2" hex head bolts, lock washers, and nuts provided.
2. When a second mower is pulled behind the first mower in tandem, then the rear hitch can be installed on the left rear axle assembly. **See figure 5.** Secure with 3/8" x 3-1/4" hex head bolts, lock washers, and nuts provided.

Note: The long tongue extension (Part # 900008) and rear hitch assembly (Part # 900009) must be ordered separately.

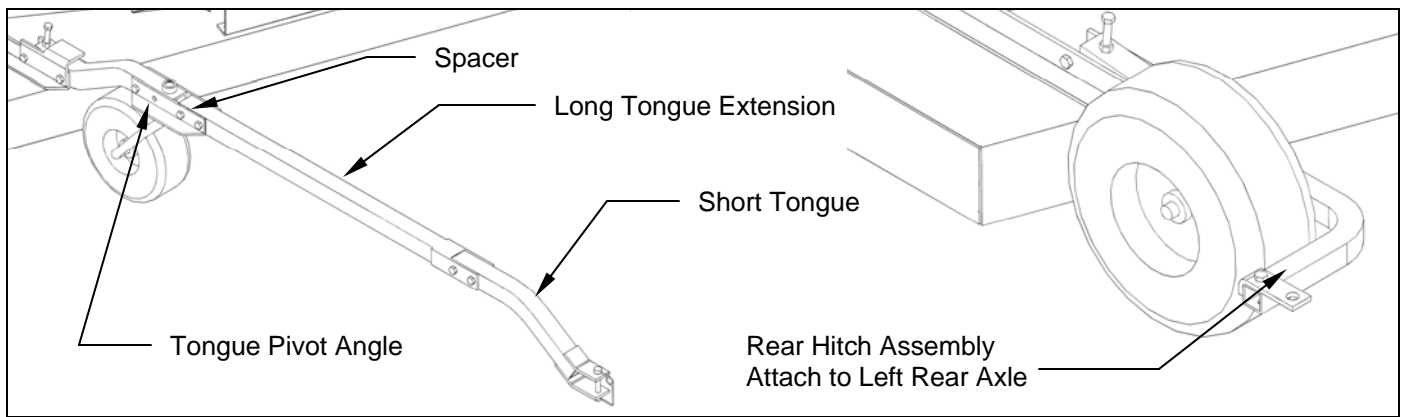

Figure 5: Long Tongue Assembly and Rear Hitch Assembly

OPERATIONS AND ADJUSTMENTS



This safety alert symbol is used to indicate safety instructions. Follow these instructions to avoid personal injury and/or property damage. Read and follow all instructions in this manual and the included engine manual.



Read all Owners Manuals before using equipment.



Know locations and functions of all controls before operating the mower.

A. HITCH CONFIGURATIONS (Refer to Figure 6)



Shut off the engine and allow the mower blades to come to a complete stop before adjusting the spreader hitch on the tow vehicle.

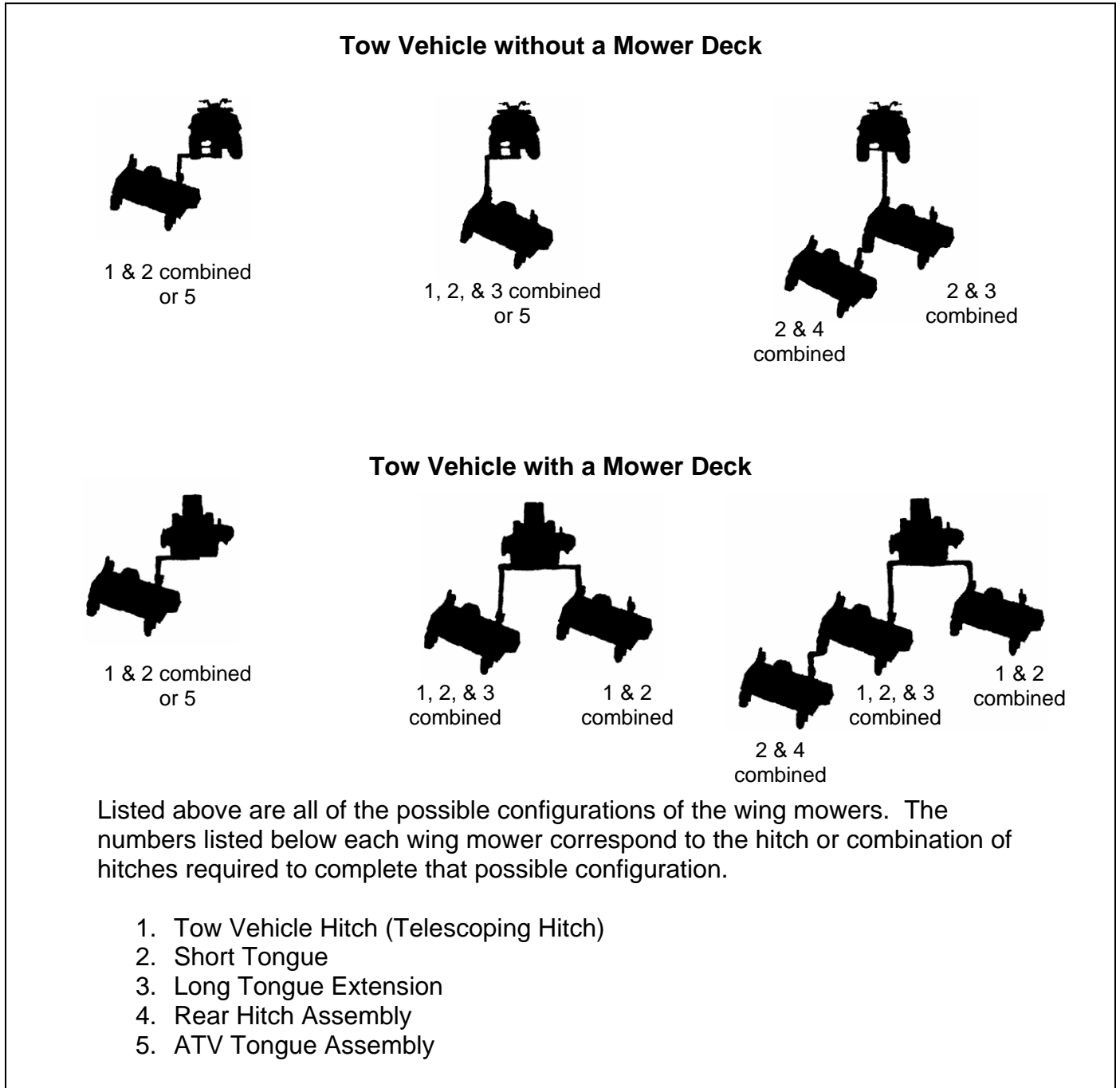

Figure 6: Wing Mower Towing Suggestions and Required Hitches

The hitching system is designed so that the wing mower can be pulled directly behind a tow vehicle without a mower deck or as a left or right wing mower when towed behind a tow vehicle with or without a mower deck.

If more than one wing mower is towed, they can be pulled in tandem or one on the left and one on the right or a combination of the above conditions until the desired cutting width is obtained.



Do not operate two wing mowers in tandem on slopes greater than 25% (1 foot rise, 4 foot run). This can create an unstable condition where the rear wing mower could push the front wing mower sideways.

When mowing large open areas, adjust the spreader hitch on the tow vehicle so that the wing mower tongue center line aligns with the outside cut line on the tow vehicle mower. When trimming around objects or mowing contours, it is best to adjust the tow vehicle hitch in to eliminate skips. The spreader hitch can be adjusted in and out to get the desired overlap to fit your mowing job.

B. ATV TONGUE CONFIGURATIONS (Refer to Figure 6)



Shut off the engine and allow the mower blades to come to a complete stop before adjusting the tongue.



When attaching the tongue to the back of the tow vehicle, tighten the screw pin shackle clevis firmly. Property damage or bodily injury may occur if the screw pin shackle clevis unturns and the wing mower becomes unattached from the tow vehicle.

The hitching system is designed so that the wing mower can be pulled directly behind a tow vehicle without a mower deck or as a left or right wing mower when towed behind a tow vehicle with or without a mower deck.

Note: When pulling the wing mower directly behind, it is most maneuverable when the hitch pivot is fastened on the left carrier arm. **See Figure 4.** When pulling the wing mower in the offset position, it is most maneuverable to have the hitch pivot fastened on the right carrier arm. **See Figure 4.**

The tongue is designed to adjust from left to right within the hitch pivot. This allows the wing mower and tow vehicle, with a mower deck, to have proper overlap. Overlap is more critical in tight areas where a lot of maneuvering is required. This overlap will eliminate most skips between the tow vehicle and wing mower. In large open areas the overlap is not as critical and should be adjusted to the user's preference.

C. ADJUSTING CUTTING HEIGHT



Shut off all engines and allow the mower blades to come to a complete stop on the wing mowers and on the tow vehicle before adjusting the cutting height.

The cutting height can be adjusted in a range from 1.0" to 4.0". This is accomplished by adjusting the height adjusting bolts on each of the four corners of the wing mower. **See Figure 7.** Turn the bolts clockwise to raise the mower cutting height and counter-clockwise to lower the mower cutting height.

When more than one mower is used at a time, it is very important to have all the mowers adjusted as close to the same cutting height as possible to obtain a high quality cutting job.

Adjust the mowers as follows:

1. Pull the mowing unit on to a smooth, level surface.
2. Adjust the tow vehicle mower deck (if applicable) to the desired cutting height and level both fore and aft and side to side.
3. Measure the distance from the level surface to the mower blade cutting edge on the tow vehicle.



Shut off tow vehicle engine and allow mower blades to stop completely before attempting to measure the cutting height.

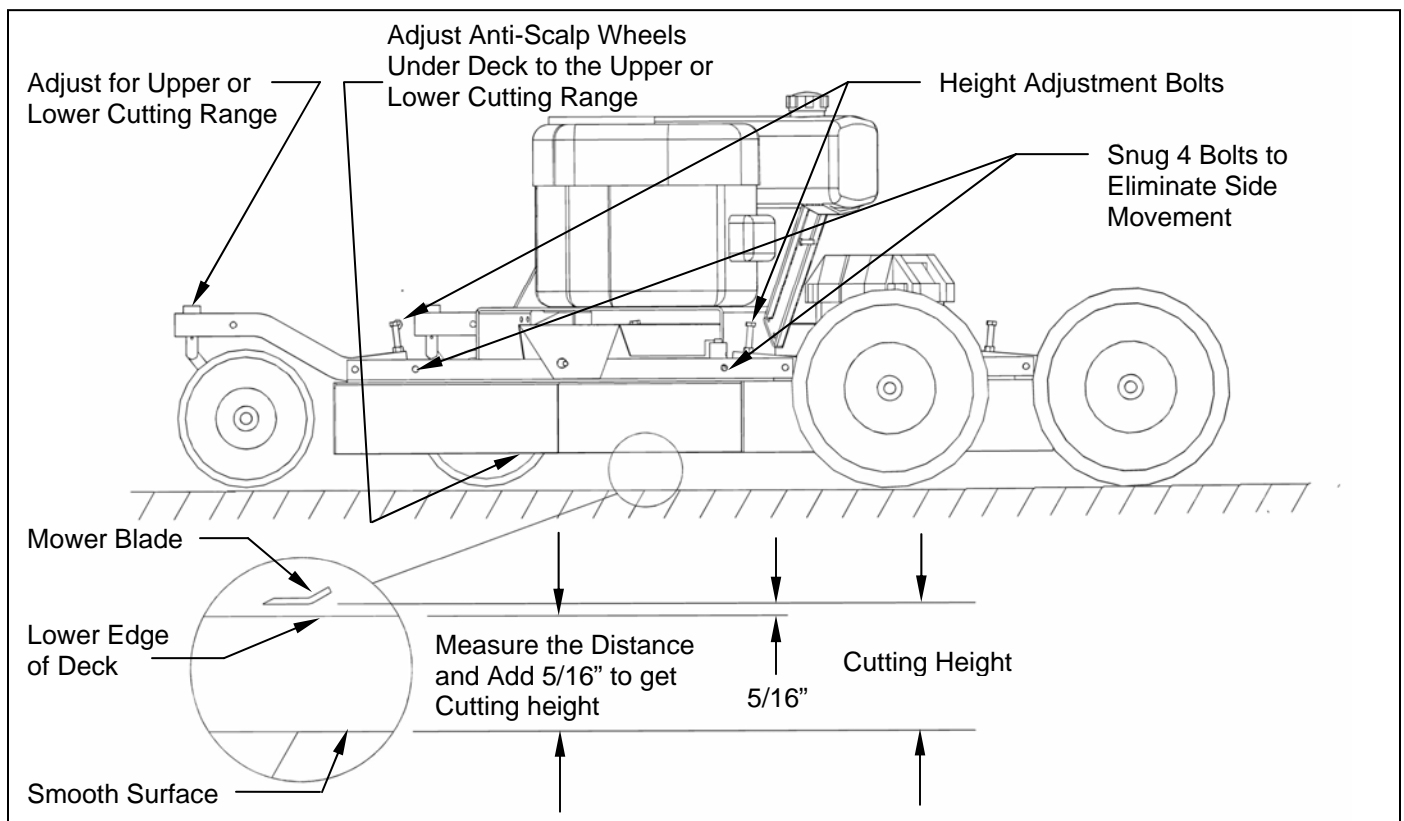

Figure 7: Adjusting Wing Mower Cutting Height

4. Adjust the cutting height on the wing mower so that it cuts at the same height as the tow vehicle mower. Adjust each corner of the wing mower so that the distance from the smooth surface to the bottom edge of the deck is equal to the cutting height minus 5/16". The mower blade cutting edge is 5/16" above the lower edge of the deck.

Note: To mow in the lower half of the cutting range, set the front caster axles in the bottom setting and set the anti-scalp wheels in the top hole. To mow in the upper half of the cutting range (original factory setting), set the front caster axles in the top setting and set the anti-scalp wheels in the bottom hole.

Note: After the cutting height has been set, be sure to tighten the pivot bolts securely to eliminate free pivoting of the front casters or rear axles. Snug the four bolts just beyond the height adjust bolt so the front casters and rear axles can be adjusted up and down but cannot move from side to side.

D. STARTING ENGINE



Set parking brake on tow vehicle.

Attach wing mower tongue to tow vehicle.



Do not start wing mower unless it is attached to the tow vehicle.

For Models H60T & C60K:

Set the choke to the desired position.

Set the throttle lever in the start position at about half throttle. The mower blades clutch will engage as the engine comes up to speed. The mower blades clutch engages at 1850 RPM.

Start engine and allow engine to warm up.

Adjust the choke to off.

Adjust engine speed to full throttle to fully engage the mower blades clutch.



Clutch overheating or failure may occur if engine is not run at full speed in heavy load conditions.



The engine full speed setting with mower blades running is 3350 RPM.

For Model H60H:

Set the throttle lever in the **choke** position to set the choke. (The choke is located beyond the full throttle detent position.)

Start engine and move throttle toward **slow** position to disengage choke. The mower blades clutch will engage as the engine comes up to speed. The mower blades clutch engages at 1850 RPM.

Slow engine speed to idle to allow engine to warm up. This will probably allow the mower blade clutch to fully disengage.

Adjust engine speed toward **fast** to fully engage the mower blade clutch. (The full throttle is located at the first detent position on the throttle control.)



Clutch overheating or failure may occur if engine is not run at full speed in heavy load conditions.



The engine full speed setting with mower blades running is 3350 RPM.

For Model E60B:

Set the throttle lever in the **choke** position to set the choke. (The throttle lever is located on the right side of the engine.)

Start engine and move throttle toward **slow** position to disengage choke.

Slow engine speed and engage mower blades clutch handle. (The clutch handle is located at the front of the mower under the engine.)

Note: Some belt squealing may occur on engagement. This is normal for a manual clutch engagement design.



If the mower's engine happens to quit while in use take care to remove the wing mower from the uncut area before attempting to engage the clutch. Also inspect the blades for any obstructions that may prevent blade engagement. Failure to do either may result in premature belt failure or even a fire.

Adjust engine speed to **fast** position for full throttle. (The full throttle is located at the detent position on the throttle control.)

E. SHUTTING OFF WING MOWER



Shift to neutral, disengage power to the mower deck, and set the parking brake before dismounting the tow vehicle.

For Models H60T & C60K:

Set the throttle to slow so the mower blades clutch will disengage.

Allow engine to cool down for a short time before turning the engine off.

For Model H60H:

Set the throttle to slow so the mower blades clutch will disengage.

Allow engine to cool down for a short time before moving the throttle control to the **stop** position.

For Model E60B:

Slow the engine speed down and disengage the clutch handle.

Allow engine to cool down for a short time before moving the throttle control to the **stop** position.

F. MOWER OPERATION



Clean or replace any safety signs that are not readable or damaged.



Remove all objects from the work area that might be picked up and thrown by the blades.



Do not mow when children and others are around.



Do not fill fuel tank while engine is running or hot.



Keep all safety shields and deflectors in place during operation.



Remove grass build up from under safety shields before each use. Do not remove safety shields while engine is running. Dry grass build up around belts and sheaves can cause fires.



Shut off engine before disconnecting the wing mower from the tow vehicle or attempting to move the wing mower by hand.



Never carry children or passengers.



Do not allow children to operate this machine.



Slow down and watch the ends of the wing mowers when making turns so objects are not struck and/or run over.

Depending on the number of wing mowers being towed, it is usually more efficient to mow the large areas first with the full system. Once the large areas are completed, mowers can be dropped off to mow narrower areas.



Look down, to the sides, and behind before and while backing to avoid backing over something or someone. Care should also be taken while backing so that the wing mower or mowers do not jackknife and damage hitches.

Backing up with one wing mower is easy. Backing becomes a greater challenge as additional wing mowers are towed. Avoid backing up by planning ahead. Make loops instead of backing.



Stop the mower blades on both the tow vehicle and all wing mowers if the tow vehicle becomes stuck or stops going forward because of loss of traction. Shut off the engines on the wing mowers before attempting to push or pull the tow vehicle.



Do not turn too sharply when the wing mowers are pulled in tandem or pulled behind a zero turn mower. Sharp turns can force the mowers into each other causing damage to the hitches.

Listen to the wing mower engines while mowing. The engines should run free and not work too hard. Working the engine too hard will cause overheating and premature failure.

Do not allow material to build up on the air inlet to the engine cooling system. If the wing mowers are towed with one on the left and one on the right side, there will be a lot of material blowing around the right wing mower engine. Special care should be taken to make sure the engine is getting enough inlet air. Do not allow the engine cooling fins under the shroud to be blocked. Air flow over the engine will be restricted causing the engine to overheat.

For Model E60B:



If the mower's engine happens to quit while in use take care to remove the wing mower from the uncut area before attempting to engage the clutch. Also inspect the blades for any obstructions that may prevent blade engagement. Failure to do either may result in premature belt failure or even a fire.

For Models H60T, H60H & C60K:

Mowing too fast in very heavy, long grass can cause the wing mower engine to pull down and disengage the blade clutch. The engine can then start to accelerate again while slipping the clutch. Small amounts of clutch slippage for a few seconds will not cause damage. If the clutch is allowed to slip for longer periods, it will overheat and could be damaged. Watch the discharge chute; if material is not being discharged, then the clutch is slipping. In normal conditions, clutch slippage will not be a problem. In most cases the clutch can be repaired by replacing the clutch springs and clutch bearing.



If the mower blades are allowed to stall out (stop turning) at engine speeds above the clutch engagement speed, this will cause the clutch to slip. If the clutch is allowed to slip for more than five minutes, the clutch will get red hot and could cause the drive belt to start burning.

G. DRIVE BELT REMOVAL AND TENSION



Shut off engine and allow mower blades to stop turning before making any adjustments or repairs.

Remove the safety shields.

Loosen the nuts on the spring-loaded idler; adjust the nut until the belt can be slipped off the idler and drive sheaves.

Slip the belt down under the drive sheave and off the blade spindle sheaves.

Install the new belt and adjust the tension as follows:

Models H60T & H60H: – See *Figure 8*.

Adjust the spring-loaded idler springs to a compressed length of $15/16$ " initially for a few hours until the belts run in; then adjust the spring to $1-1/8$ " to $1-1/4$ " compressed length.

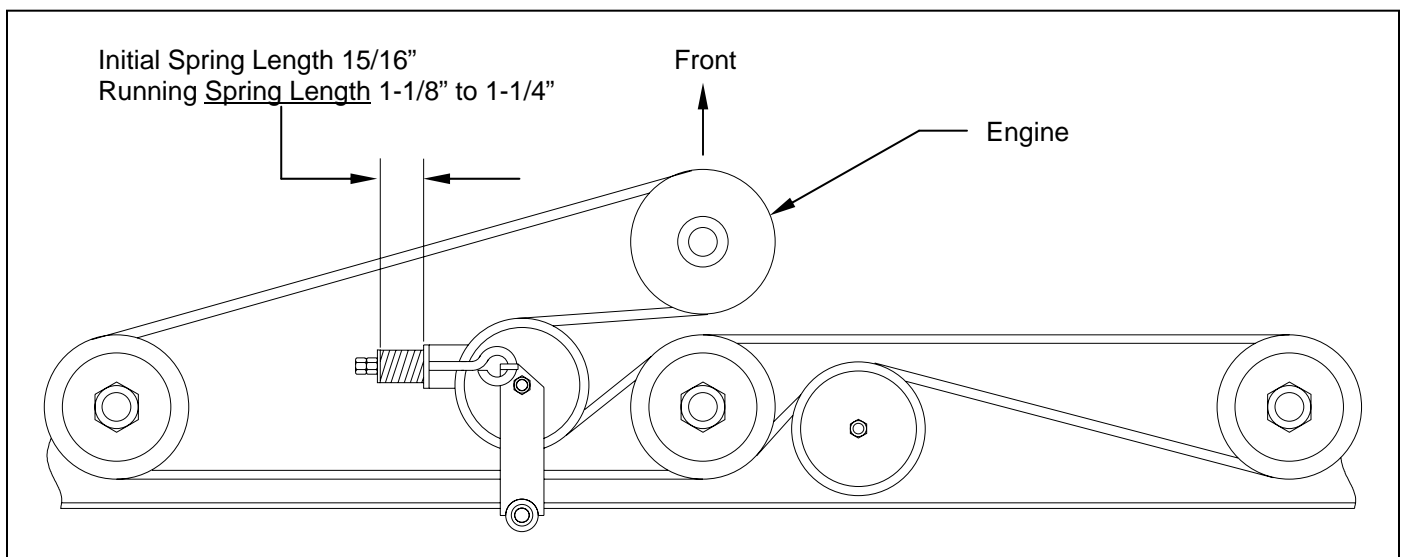

Figure 8: Belt Pattern and Spring Adjustment (Model H60T & H60H)

Model C60K: – See *Figure 9*.

Adjust the spring-loaded idler springs to a compressed length of $15/16$ " initially for a few hours until the belts run in; then adjust the spring to $1-1/8$ " to $1-1/4$ " compressed length.

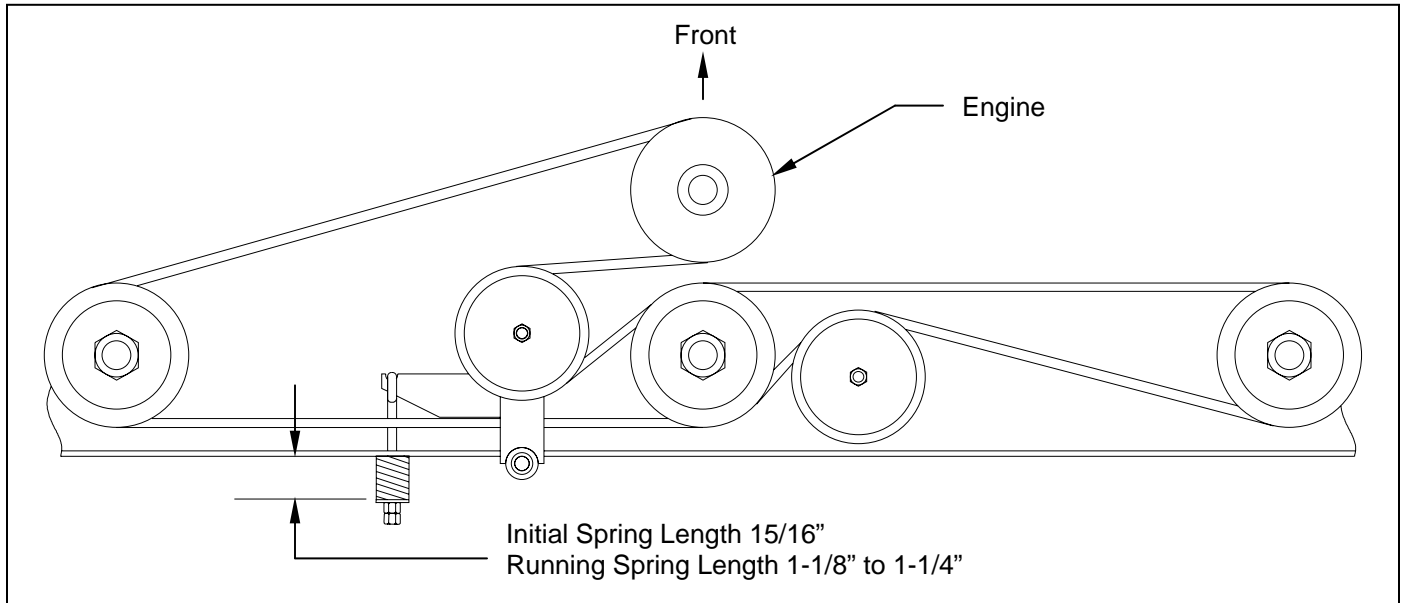

Figure 9: Belt Pattern and Spring Adjustment (Model C60K)

For Model E60B: - See Figure 10.

With the clutch engaged, adjust the nuts on the spring loaded idler adjuster bolt until the length of the spring is between 2-1/4" and 2-3/8". This model comes with a belt brake when the clutch is disengaged. This is a safety feature to stop the blades from turning after the clutch is disengaged. To ensure that the brake works properly the spring length must be set correctly. With the clutch disengaged make sure the spring length is no more than 2-3/4".



The brake stud must be adjusted. If the brake stud is not adjusted correctly, the blades will still spin even though the clutch may be in the disengaged position. Always shut mower engine off before servicing.

To the adjust brake place clutch in the engaged position. Loosen the bolt on the top of the brake stud. Slide the brake stud in the slot until there is about 1/2" of clearance between the belt and the brake stud. Tighten the bolt at the top of the brake stud.



If brake stud is not set in correct position underbraking or overbraking may occur. If overbraking occurs premature belt failure could occur and possible fire due to overheating.

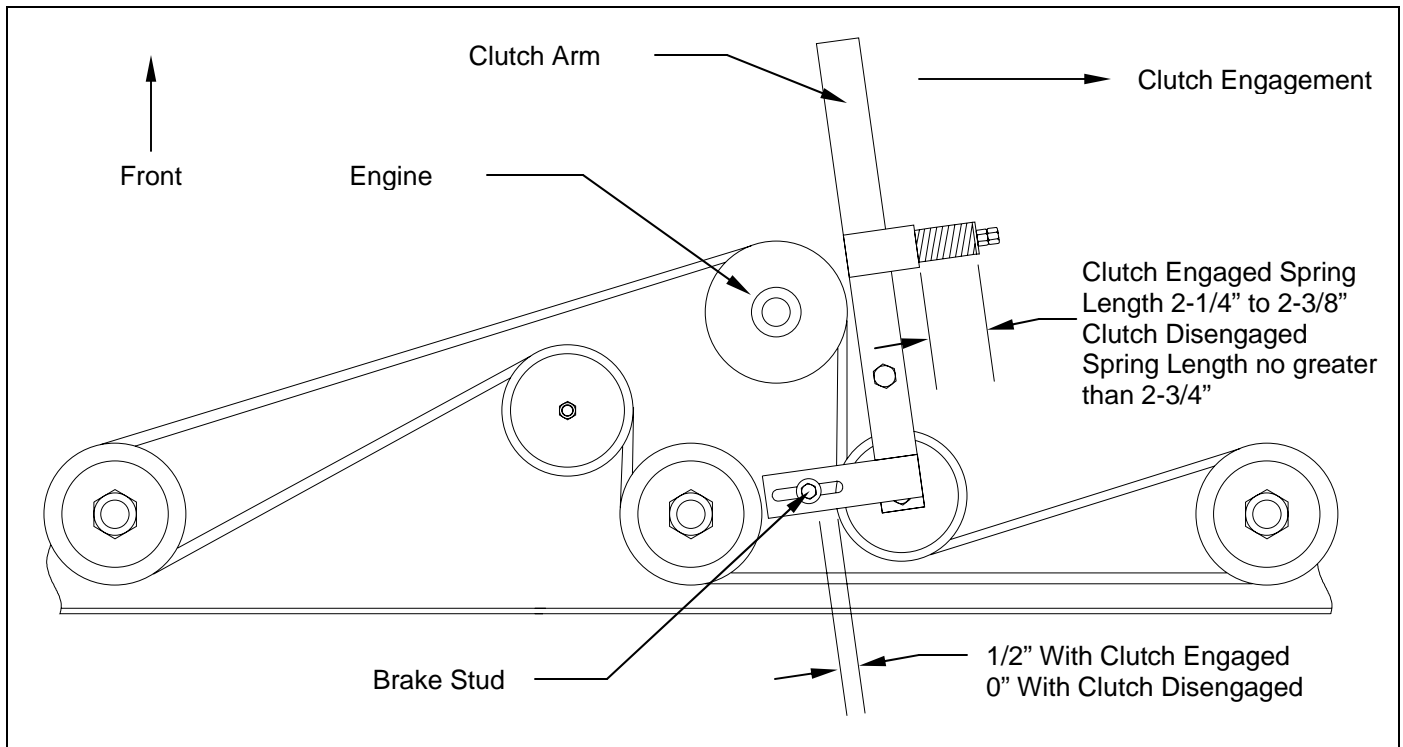

Figure 10: Belt Pattern and Spring Adjustment (Model E60B)

H. MOWER BLADE REMOVAL, BALANCING & INSTALLATION



Sharp blades can cause bodily injury if not handled properly.

When removing the blade, it is recommended that a block of wood be placed between the blade and the underside of the mower deck. This will allow the removal of the blade without the need to hold the blade by hand.



Always balance the mower blades each time they are sharpened.

Out of balance mower blades cause excess vibrations which lead to premature bearing failures, bolts coming loose, and overall deterioration of the wing mowers.



Always properly tighten the blade bolts to the specified torque. Failure to do so can lead to unwanted loosening of the blade and damage to the blade holding saddle.

The Models E60B, H60T and H60H use the Kunz Engineering Part # (202134) blade bolt. This particular hex head bolt is a 3/8" – 24NF x 7/8" long, grade 5 and it's proper torque is 35 ft-lbs. The Model C60K uses the Kunz Engineering Part # (202136) blade bolt. This particular hex head bolt is a 1/2" – 20NF x 1.00" long, grade 5 and it's proper torque is 85 ft-lbs.

To ease in the blade installation process, use the same block of wood and method used during the removal of the blades.

I. LUBRICATION

There are ten lubrication points on the wing mower -- one spring-loaded idler pivot, two caster wheel pivots, four wheels, and three blade spindles. Lubricate at approximately 10 hr. intervals or more often as required in dusty conditions. Lubricate the blade spindles 2-5 pumps every 50 hours. (The bearings have trash guard seals to hold the seals in place during lubrication.) Lubricate with a high grade of pressure gun grease.

Note: Do not over grease blade spindles. Blade spindles are initially greased at the factory. Greasing before 50 hrs. may cause bearing seal damage which will result in premature bearing failure.

J. TIRE PRESSURE

To reduce wing mower bounce on rough yards, the rear tire pressure can be reduced so they feel slightly soft (approximately 15 PSI) when they are stepped on.

K. TRANSPORTATION OF MOWER

When transporting the mowers between jobs turn off the fuel shut-off valve. On Models H60T, H60H and C60K the fuel shut-off valve is located below the fuel tank. On the Model E60B the fuel shut-off valve is located along the right side of the engine.

L. STORAGE

If the mower is stored outside, the engine should be covered to prevent water from getting inside the engine during heavy rainstorms. See the Engine Manual for additional information.

WING MOWER SPECIFICATIONS

	<u>Model H60T</u>	<u>Model C60K</u>
<u>ENGINE:</u>		
Engine Make	Tecumseh Enduro	Kohler Command Pro
Engine Model	OHV130-EXE	CV 15S
Cylinders	1	1
Cycles	4	4
Crankshaft	Vertical	Vertical
Engine HP	13	15
Bore	3.31"	3.55"
Stroke	2.53"	2.64"
Displacement	21.82 cu.in.	26 cu.in.
Oil Capacity	1 U.S. qts.	2 U.S. qts.
Crankshaft Dia.	1"	1"
Key Slot	1/4"	1/4"
Crankshaft Length	3.15"	3.15"
Threaded Hole in End of Crankshaft	7/16-20	7/16-20
Engine Mounting Bolts	5/16-18 x 1-1/2	M8 x 1.25 - 25
Starter	Electric	Electric
Choke	Manual	Manual
<u>MOWER:</u>		
Fuel Tank	3.75 gal.	3.75 gal.
Effective Cutting Width	58"	58"
Deck Construction	11 ga. Welded steel	10 ga. Welded steel
Cutting Height	1" to 4"	1" to 4"
Height Adjustment	4 screws	4 screws
Anti-Scalp Wheels (3" O.D. x 1-1/4" wide)	4 in front, 2 in rear	4 in front, 2 in rear
Rear Wheels (Fixed) (2 ply Turf Pnuematic)	2 13/500 x 6	2 13/500 x 6
Front Wheels (Caster) (Semi Pnuematic)	2 9/350 x 4	2 9/350 x 4
Blade Dia.	3-20"	3-20"
Engine Speed, Blades Running	3350 RPM	3350 RPM
<u>CLUTCH TYPE</u>		
Engagement Speed	1850 RPM	1850 RPM
<u>DIMENSIONS</u>		
Length	52"	52"
Width	72-1/4"	72-1/4"
Height	24-1/2"	25"
Weight	325#	380#
<u>TOUCH-UP PAINT COLOR</u>		
	Pewter Gray, Krylon #1606	Pewter Gray, Krylon #1606

WING MOWER SPECIFICATIONS

	Model <u>E60B</u>	Model <u>H60H</u>
<u>ENGINE:</u>		
Engine Make	Briggs & Stratton	Honda
Engine Model	Intek	GXV390
Cylinders	1	1
Cycles	4	4
Crankshaft	Vertical	Vertical
Engine HP	13	13
Bore	3.44"	3.46"
Stroke	2.26"	2.52"
Displacement	21.0 cu. in.	23.7 cu. in.
Oil Capacity	1.5 U.S. qts	1.2 U.S. qts
Crankshaft Dia.	1.0"	1.0"
Key Slot	1/4"	1/4"
Crankshaft Length	3.15"	3.12"
Threaded Hole in End of Crankshaft	7/16 - 20	7/16 - 20
Engine Mounting Bolts	5/16-18 x 1-1/2	5/16-18 x 1-1/2" and 5/16-24 x 1"
Starter	Manual	Manual
Choke	With Throttle Control	With Throttle Control
<u>MOWER:</u>		
Fuel Tank	3 Quart	3-3/4 Gal.
Effective Cutting Width	58"	58"
Deck Construction	11 ga. Welded steel	11 ga. Welded steel
Cutting Height	1" to 4"	1" to 4"
Height Adjustment	4 screws	4 screws
Anti-Scalp Wheels (3" O.D. x 1-1/4" wide)	4 in front, 2 in rear	4 in front, 2 in rear
Rear Wheels (Fixed) (2 ply Turf Pnuematic)	2 13/500 x 6	2 13/500 x 6
Front Wheels (Caster) (Semi Pnuematic)	2 9/350 x 4	2 9/350 x 4
Blade Dia.	3-20"	3-20"
Engine Speed, Blades Running	3350 RPM	3350 RPM
<u>CLUTCH TYPE</u>		
Engagement Speed	Manual	1850 RPM
<u>DIMENSIONS</u>		
Length	52"	52"
Width	72-1/4"	72-1/4"
Height	24-1/2"	24-1/2"
Weight	335 lbs	325 lbs
<u>TOUCH-UP PAINT COLOR</u>		
	Pewter Gray, Krylon #1606	Pewter Gray, Krylon #1606

ACREASE WING MOWER PARTS MODEL C60K

<u>Item</u>	<u>Part #</u>	<u>Description</u>	<u>C60K</u>
1	202135	Hex Head Bolt, 3/8" x 3" Fully Threaded	4
2	204000	Shoulder Bolt, 1/2" x 1-5/8" Shoulder Length	6
3	222005	Worm Drive Hose Clamp (7-7/8" to 9-1/8" Clamping Dia.	2
4	225000	Compression Spring, 1-1/2"L x 1-3/32" O.D. x .135" Wire dia.	1
5	226000	Plastic Wheel, 3" O.D. x 1/2" I.D. x 1-1/4" Wide	6
6	226001	Offset Wheel Assy., 13/500 x 6, 2 Ply Turf	2
7	226002	Centered Wheel Assy., 9/350 x 4, Semi Pneumatic	2
8	238002	"V" Belt, B Section, 127" O.C. Dayco B124 Super II	1
9	241001	Flat Idler, 4" O.D. x 3/8" Hole	2
10	258016	Centrifugal Clutch	1
	258017	Clutch Shoe (3)	~
	225004	Spring, 1850 RPM Engagement (3) (Blue)	~
	243004	Bearing (1)	~
11	258014	Spindle Assy.	3
	900046	Spindle Shaft (1)	~
	600088	Sheave Spacer (2" Long) (1)	~
	900048	Housing Assy. (With Two Bearings) (1)	~
	243003	Bearing (2)	~
	600086	Bearing Spacer (1-5/8" Long) (1)	~
	241007	Sheave, 5-1/4" (1)	~
12	259001	Offset Mower Blade, 2" Wide, 20" Long, 1/2" Hole	3
13	264001	Ignition Switch	1
14	264002	Solenoid	1
15	264003	Hour/Tack Meter	1
16	269001	Throttle Control, 15"	1
17	269004	Choke Control, 14"	1
18	275001	Control Panel Decal, Starting Instructions	1
18	275002	Warning Decal General	1
18	275003	Danger Decal, Cut Finger	2
18	275007	Warning Decal, Belt Sheild	2
18	275017	Name Decal, AcrEase	2
19	277002	Rubber Grommet	7
20	277010	Fuel Tank, 3.75 Gal. (Plastic) (Use Gas Cap 277013)	1
21	277013	Gas Cap (For Fuel Tank 277010)	1
22	600048	Solenoid Support	1
23	600059	Caster Axle	2
24	600062	Belt Sheild L.H.	1
24	600063	Belt Sheild R.H. (Discharge Side)	1
25	600065	Engine Support Bracket	1
26	600188	Caster Support Stop	1
27	900005	Rear Axle	2
28	900021	Caster Support	2
29	900023	Control Panel	1
30	900025	Idler Arm Assy.	1
	243000	Bronze Bearing, 1/2" I.D. x 3/4" O.D. x 1-1/2" Long	~
31	900029	Mower Deck	1
32	900049	Battery Box Assy.	1
33	900051	Depth Gage	1
34	900052	Tank Support	1

MODEL C60K

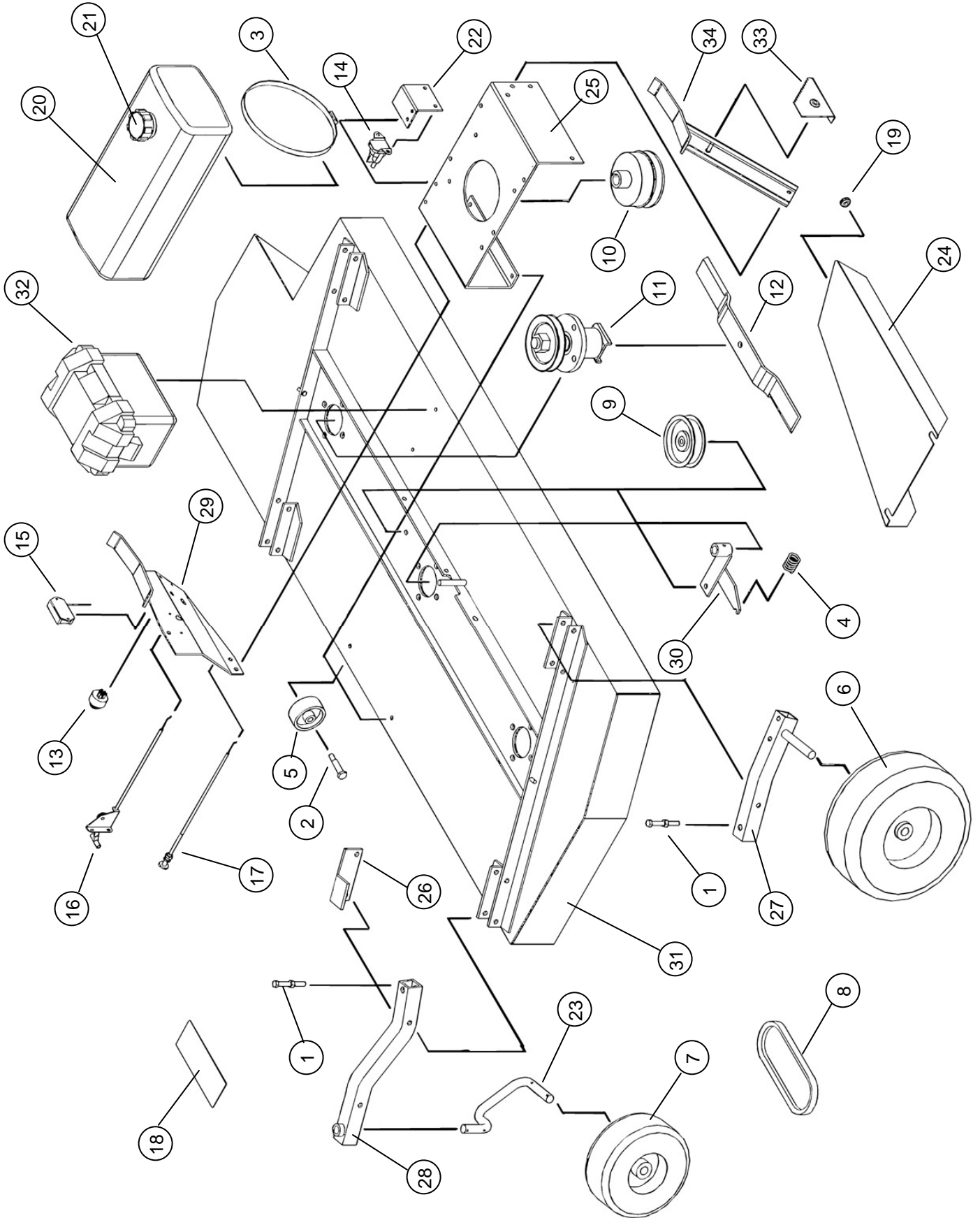

ACREASE WING MOWER PARTS MODEL H60T

<u>Item</u>	<u>Part #</u>	<u>Description</u>	<u>H60T</u>
1	202135	Hex Head Bolt, 3/8" x 3" Fully Threaded	4
2	204000	Shoulder Bolt, 1/2" x 1-5/8" Shoulder Length	6
3	222005	Worm Drive Hose Clamp (7-7/8" to 9-1/8" Clamping Dia.	2
4	225000	Compression Spring, 1-1/2"L x 1-3/32" O.D. x .135" Wire dia.	1
5	226000	Plastic Wheel, 3" O.D. x 1/2" I.D. x 1-1/4" Wide	6
6	226001	Offset Wheel Assy., 13/500 x 6, 2 Ply Turf	2
7	226002	Centered Wheel Assy., 9/350 x 4, Semi Pneumatic	2
8	238002	"V" Belt, B Section, 127" O.C. Dayco B124 Super II	1
9	241001	Flat Idler, 4" O.D. x 3/8" Hole	2
10	258016	Centrifugal Clutch	1
	258017	Clutch Shoe (3)	~
	225004	Spring, 1850 RPM Engagement (3) (Blue)	~
	243004	Bearing (1)	~
11	258013	Spindle Assy.	3
	900045	Spindle Shaft (1)	~
	600087	Sheave Spacer (1-1/4" Long) (1)	~
	900048	Housing Assy. (With Two Bearings) (1)	~
	243003	Bearing (2)	~
	600086	Bearing Spacer (1-5/8" Long) (1)	~
	241007	Sheave, 5-1/4" (1)	~
12	259000	Offset Mower Blade, 2" Wide, 20" Long, 3/8" Hole	3
13	264001	Ignition Switch	1
14	264002	Solenoid	1
15	264003	Hour/Tack Meter	Optional
16	269000	Choke Control, 20"	1
17	269001	Throttle Control, 15"	1
18	275001	Control Panel Decal, Starting Instructions	1
18	275002	Warning Decal General	1
18	275003	Danger Decal, Cut Finger	2
18	275007	Warning Decal, Belt Sheild	2
18	275017	Name Decal, AcrEase	2
19	277002	Rubber Grommet	7
20	277010	Fuel Tank, 3.75 Gal. (Plastic) (Use Gas Cap 277013)	1
21	277013	Gas Cap (For Fuel Tank 277010)	1
22	600048	Solenoid Support	1
23	600059	Caster Axle	2
24	600062	Belt Sheild L.H.	1
24	600063	Belt Sheild R.H. (Discharge Side)	1
25	600082	Engine Support Bracket	1
26	600188	Caster Support Stop	1
27	900005	Rear Axle	2
28	900021	Caster Support	2
29	900023	Control Panel	1
30	900040	Idler Arm Assy.	1
	243000	Bronze Bearing, 1/2" I.D. x 3/4" O.D. x 1-1/2" Long	~
31	900042	Mower Deck	1
32	900049	Battery Box Assy.	1
33	900051	Depth Gage	1
34	900052	Tank Support	1

MODEL H60T

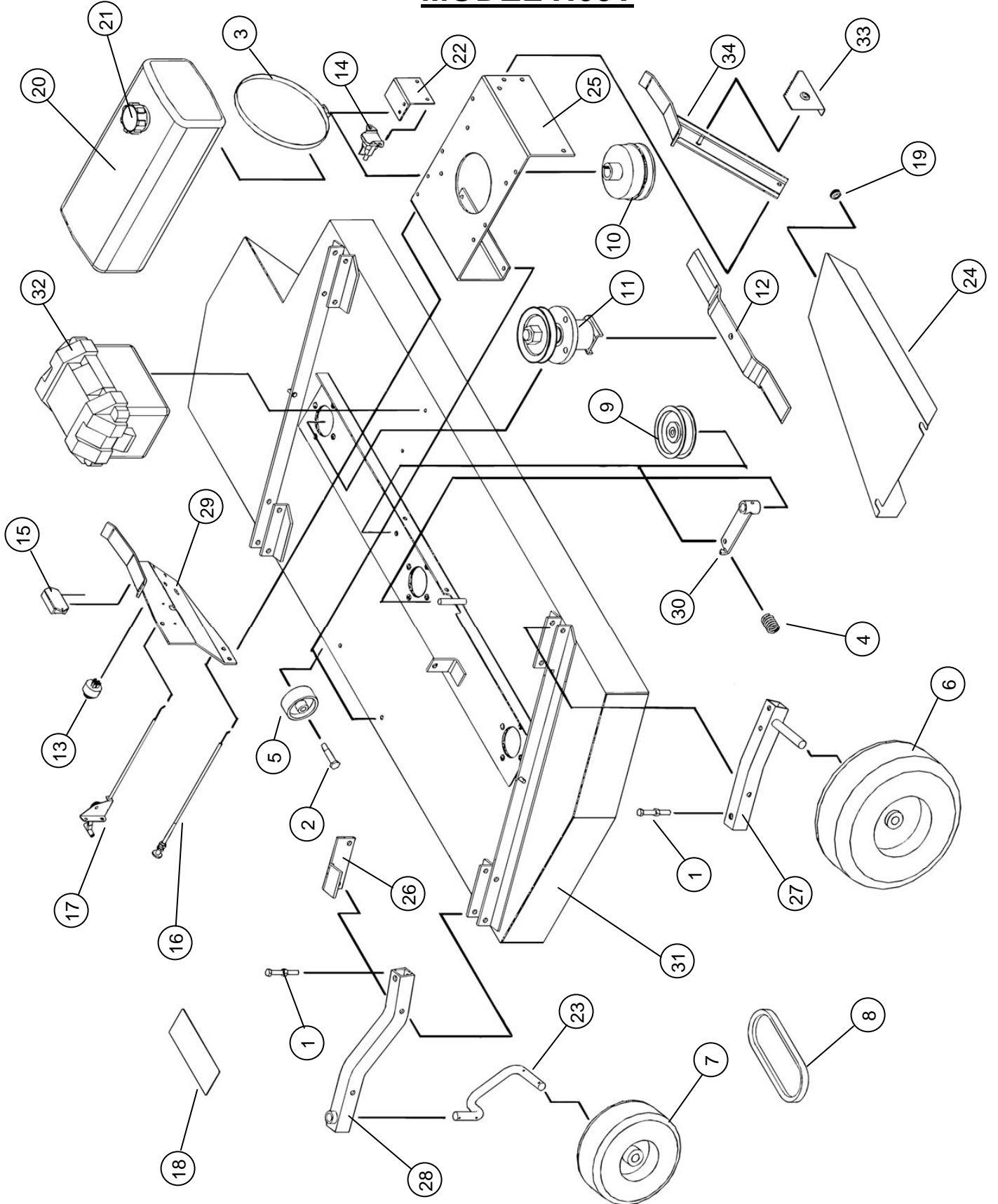

ACREASE WING MOWER PARTS MODEL E60B

<u>Item</u>	<u>Part #</u>	<u>Description</u>	<u>E60B</u>
1	202135	Hex Head Bolt, 3/8" x 3" Fully Threaded	4
2	204000	Shoulder Bolt, 1/2" x 1-5/8" Shoulder Length	6
3	225003	Compression Spring, 3"L x 1-3/32" O.D. x .055" Wire dia.	1
4	226000	Plastic Wheel, 3" O.D. x 1/2" I.D. x 1-1/4" Wide	6
5	226001	Offset Wheel Assy., 13/500 x 6, 2 Ply Turf	2
6	226002	Centered Wheel Assy., 9/350 x 4, Semi Pneumatic Slick	2
7	238005	"V" Belt, B Section, 115" O.C. Dayco B112 Super II	1
8	241001	Flat Idler, 4" O.D. x 3/8" Hole	2
9	241006	"V" Sheave, 5" Dia. 1" Bore	1
10	258013	Spindle Assy.	3
	900045	Spindle Shaft (1)	
	600087	Sheave Spacer (1-1/4" Long) (1)	
	900048	Housing Assy. (With Two Bearings) (1)	
	243003	Bearing (2)	
	600086	Bearing Spacer (1-5/8" Long) (1)	
	241007	Sheave, 5-1/4" (1)	
11	259000	Offset Mower Blade, 2" Wide, 20" Long, 3/8" Hole	3
12	269005	Throttle Control	1
13	269006	Throttle Wire	1
14	275002	Warning Decal General	1
14	275003	Danger Decal, Cut Finger	2
14	275006	Clutch Engagement Decal	1
14	275007	Warning Decal, Belt Sheild	2
14	275013	Throttle Control Decal	1
14	275017	Name Decal	2
15	277002	Rubber Grommet	6
16	277011	Handle Grip	1
17	600059	Caster Axle	2
18	600062	Belt Sheild L.H.	1
18	600063	Belt Sheild R.H. (Discharge Side)	1
19	600071	Spacer, 1.38" O.D. x 1.33" Wall x 2.19" Long	1
20	600105	Engine Support Bracket	1
21	600136	Brake Stud	1
22	600161	Throttle Support	1
23	600188	Caster Support Stop	1
24	900005	Rear Axle	2
25	900021	Caster Support	2
26	900053	Mower Deck	1
27	900055	Clutch Arm	1
28	900060	Idler Arm Assy.	1
	243005	Bronze Bearing, 1/2" I.D. x 3/4" O.D. x .75" Long	2

MODEL E60B

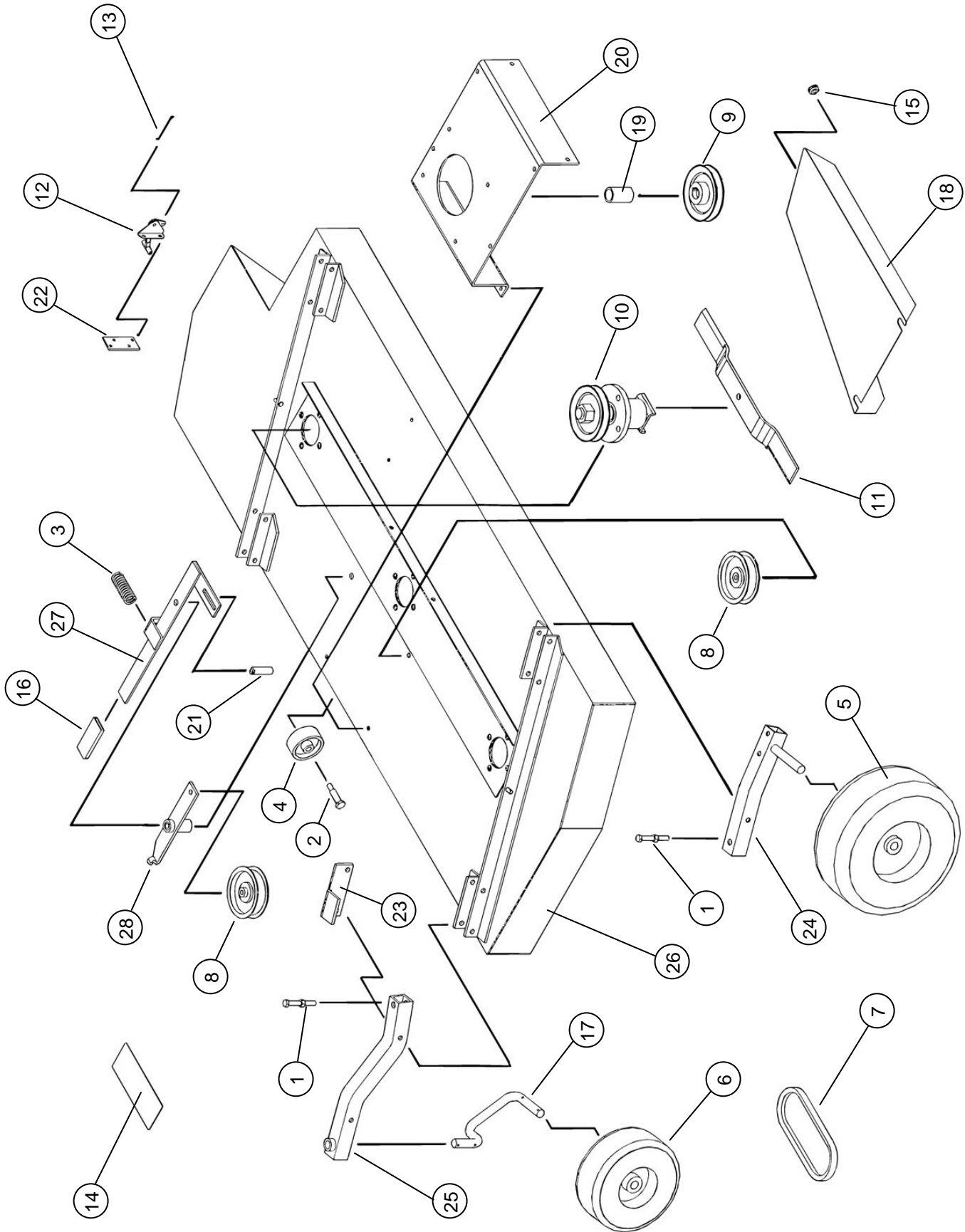

ACREASE WING MOWER PARTS MODEL H60H

<u>Item</u>	<u>Part #</u>	<u>Description</u>	<u>Quantity</u>
1	202135	Hex Head Bolt, 3/8" x 3" Fully Threaded	4
2	204000	Shoulder Bolt, 1/2" x 1-5/8" Shoulder Length	6
3	222005	Worm Drive Hose Clamp (7-7/8" to 9-1/8" Clamping Dia.	2
4	225000	Compression Spring, 1-1/2"L x 1-3/32" O.D. x .135" Wire dia.	1
5	226000	Plastic Wheel, 3" O.D. x 1/2" I.D. x 1-1/4" Wide	6
6	226001	Offset Wheel Assy., 13/500 x 6, 2 Ply Turf	2
7	226002	Centered Wheel Assy., 9/350 x 4, Semi Pneumatic	2
8	238002	"V" Belt, B Section, 127" O.C. Dayco B124 Super II	1
9	241001	Flat Idler, 4" O.D. x 3/8" Hole	2
10	258016	Centrifugal Clutch	1
	258017	Clutch Shoe (3)	~
	225004	Spring, 1850 RPM Engagement (3) (Blue)	~
	243004	Bearing (1)	~
11	258013	Spindle Assy.	3
	900045	Spindle Shaft (1)	~
	600087	Sheave Spacer (1-1/4" Long) (1)	~
	900048	Housing Assy. (With Two Bearings) (1)	~
	243003	Bearing (2)	~
	600086	Bearing Spacer (1-5/8" Long) (1)	~
	241007	Sheave, 5-1/4" (1)	~
12	259000	Offset Mower Blade, 2" Wide, 20" Long, 3/8" Hole	3
13	269009	Throttle Control, 27"	1
14	275002	Warning Decal General	1
14	275003	Danger Decal, Cut Finger	2
14	275007	Warning Decal, Belt Sheild	2
14	275012	Control Panel Decal, Starting Instructions	1
14	275013	Throttle Control Decal (Slow, Fast & Choke)	1
14	275017	Name Decal, AcrEase	2
15	277002	Rubber Grommet	7
16	277010	Fuel Tank, 3.75 Gal. (Plastic) (Use Gas Cap 277013)	1
17	277013	Gas Cap (For Fuel Tank 277010)	1
18	600059	Caster Axle	2
19	600062	Belt Sheild L.H.	1
19	600063	Belt Sheild R.H. (Discharge Side)	1
20	600082	Engine Support Bracket	1
21	600188	Caster Support Stop	1
22	900005	Rear Axle	2
23	900021	Caster Support	2
24	900040	Idler Arm Assy.	1
	243000	Bronze Bearing, 1/2" I.D. x 3/4" O.D. x 1-1/2" Long	~
25	900042	Mower Deck	1
26	900051	Depth Gage	1
27	900052	Tank Support	1
28	900089	Control Panel	1

MODEL H60H

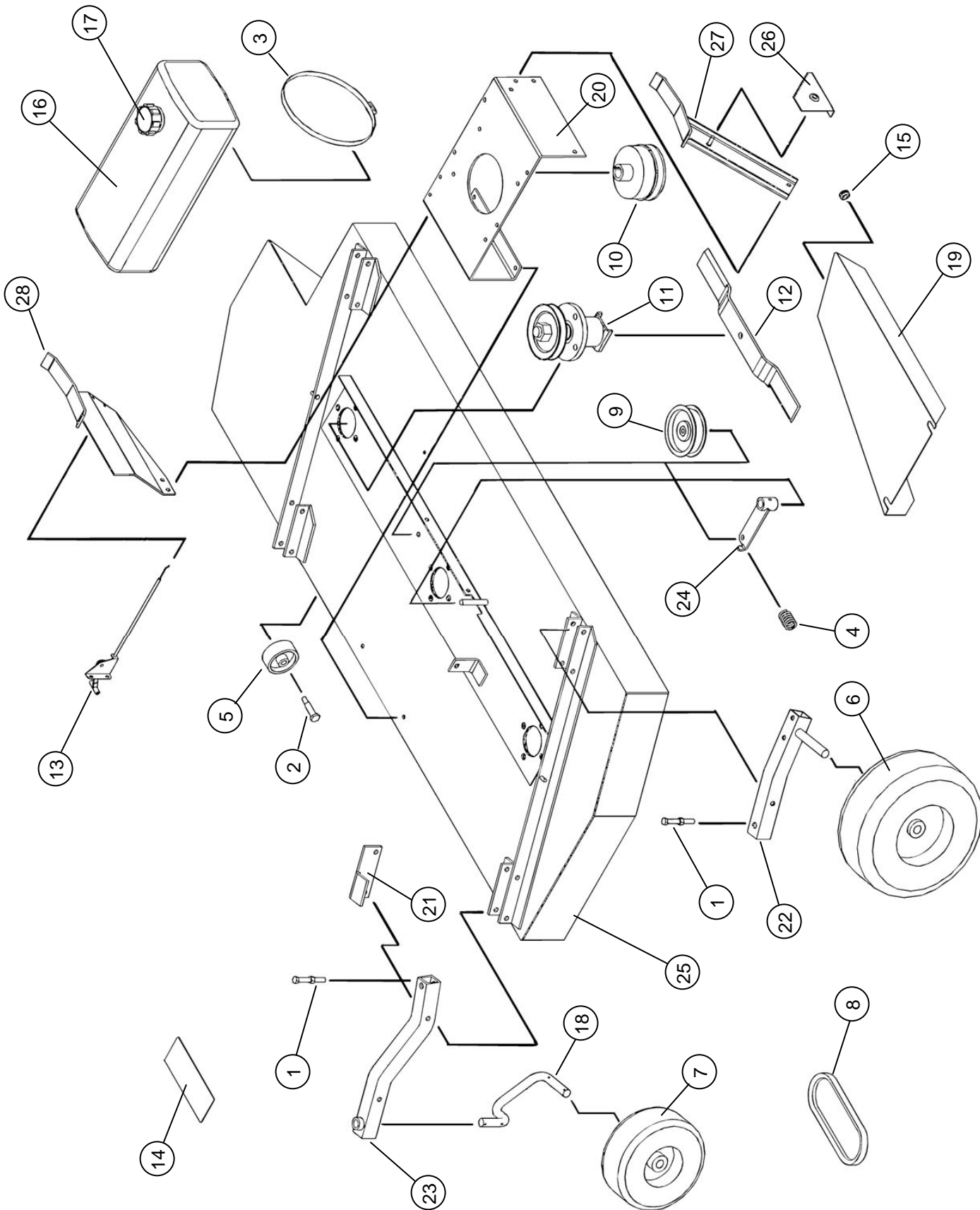

LAWN & GARDEN HITCH PARTS

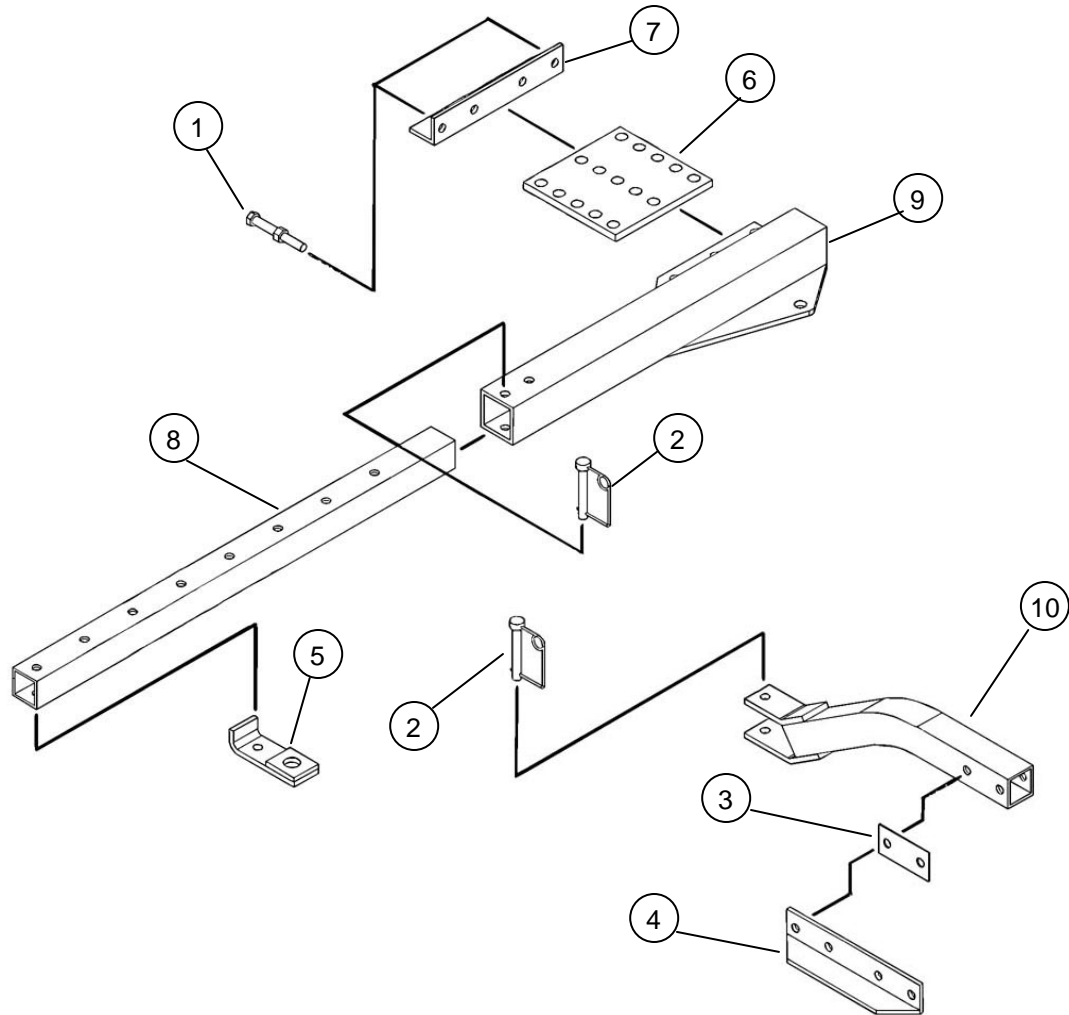

PARTS LIST

<u>Item</u>	<u>Part #</u>	<u>Description</u>	<u>Quantity</u>	
			<u>H60T, E60B & H60H</u>	<u>C60K</u>
1	202135	Hex Head Bolt, 3/8" x 3" Fully Threaded	2	2
2	216002	Wire Lock Pin, 5/16" x 2-1/4" Opening	1	0
2	216006	Wire Lock Pin, 3/8" x 2-1/4" Opening	1	2
3	600001	Spacer	1	1
4	600002	Tongue Pivot Angle	2	2
5	600006	Hitch Flat (5/16" Mounting Hole)	1	0
5	900050	Hitch Draw Bar	0	1
6	600008	Hitch Adaptor Plate	1	0
6	600044	Hitch Adaptor Plate	0	1
7	600009	Hitch Stop Angle	1	1
8	600010	Hitch Extension	1	0
8	600043	Hitch Extension	0	1
9	900001	Telescope Hitch	1	0
9	900026	Telescope Hitch	0	1
10	900007	Short Tongue	1	1

ATV TONGUE PARTS

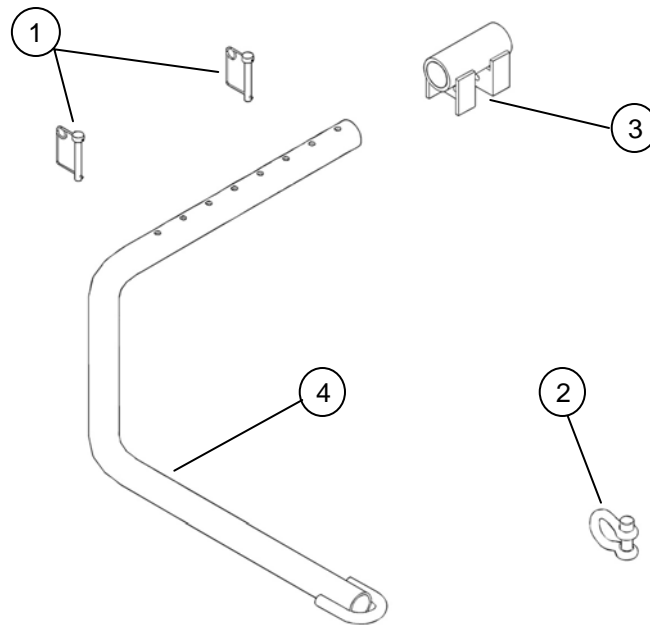

PARTS LIST

<u>Item</u>	<u>Part #</u>	<u>Description</u>	<u>Quantity</u>
1	216002	Wire Lock Pin .31" X 2.50"	2
2	216009	Screw Pin Shackle Clevis	1
3	900057	Hitch Pivot	1
4	900082	Tongue	1

OPTIONAL HITCH PARTS

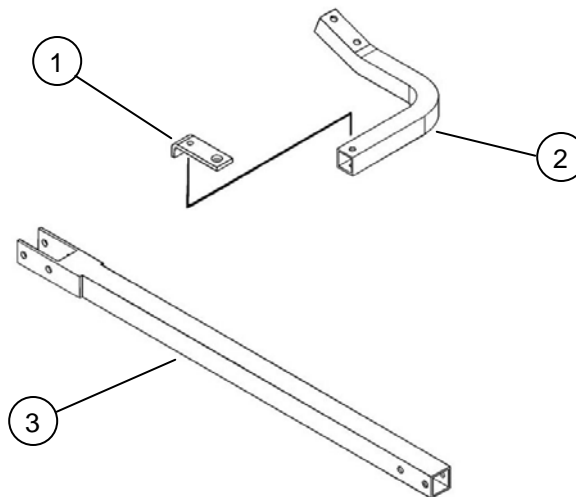

PARTS LIST

<u>Item</u>	<u>Part #</u>	<u>Description</u>	<u>Quantity</u>
1	600006	Hitch Flat (5/16" Mounting Hole)	1
2	600020	Rear Hitch Tube	1
3	900000	Long Tongue Extension	1

SAFETY SIGNS AND LOCATIONS

WARNING

AVOID INJURY OR DEATH

- Read and follow owner's manual.
- Know location and function of all controls.
- Before starting engine, remove grass build-up from under safety shields.
- Before starting engine, attach machine to tow vehicle.
- Shut off engine before disconnecting machine from tow vehicle or attempting to move machine by hand.
- Do not fill fuel tank while engine is running or hot.
- If tow vehicle stops going forward, stop engine on towed mower before trying to push or pull tow vehicle.
- When making turns, slow down and watch ends of towed mower.
- Never carry children or passengers.
- Look down, to the sides, and behind before and while backing.
- Do not allow children to operate this machine.
- Do not mow when children and others are around.
- Remove all objects that may be thrown by blade.
- Keep safety shields and deflectors in place.
- Shut off engine while in transport.
- Before dismounting tow vehicle: shift to neutral, disengage power to tow vehicle mower, and set parking brake.
- Be sure blades, engine and moving parts are stopped before placing hands or feet near blade or performing service.



275003 –
Danger Decal,
Cut Hand & Foot



275007 –
Warning Decal,
Belt Shield

275002 – Warning Decal,
General

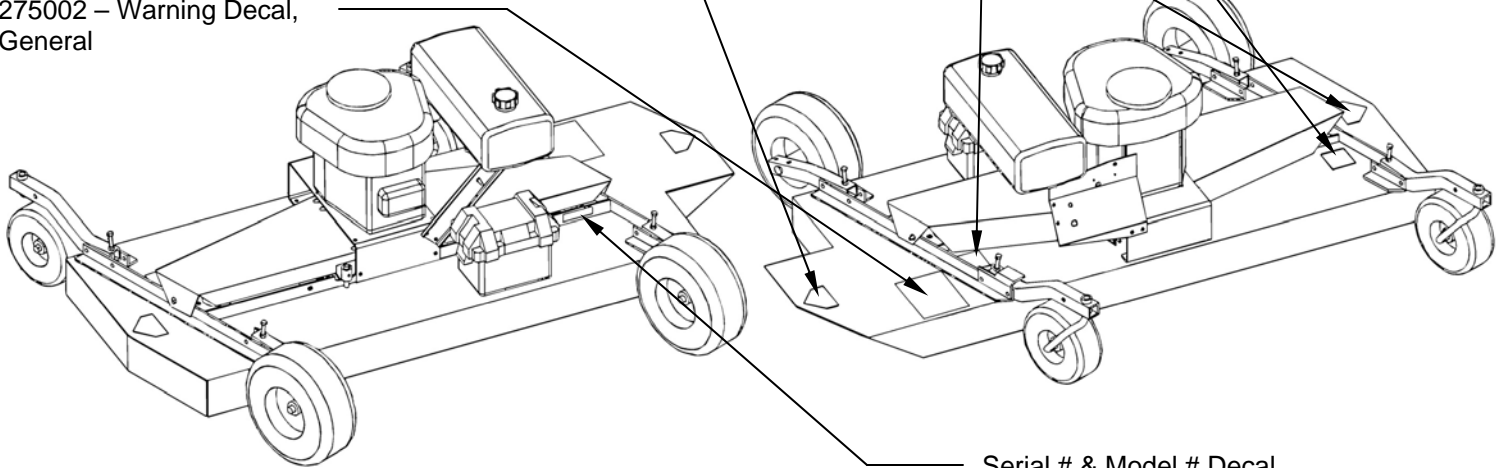

Serial # & Model # Decal



Clean or Replace Any Safety Signs That Are not Readable or Damaged

Replacement decals can be purchased from your local dealer or

Kunz Engineering Inc.
Mendota, IL 61342
(815) 539-6954
www.kunzeng.com

OPTIONAL EQUIPMENT

OPTIONAL FLOATATION KIT

This optional floatation kit features an extra front and back tire that can be bolted in the center section of the mower deck. This is a great anti-scalp feature that helps to carry the center section of the mower deck and works well in the following applications:

- Rough, uneven ground where added floatation is needed.
- Hard to reach areas at the water's edge around ponds.
- Extending over a creek banks edge.
- Steep road banks where added traction is needed.
- Gradual crowned or peaked areas in a lawn.

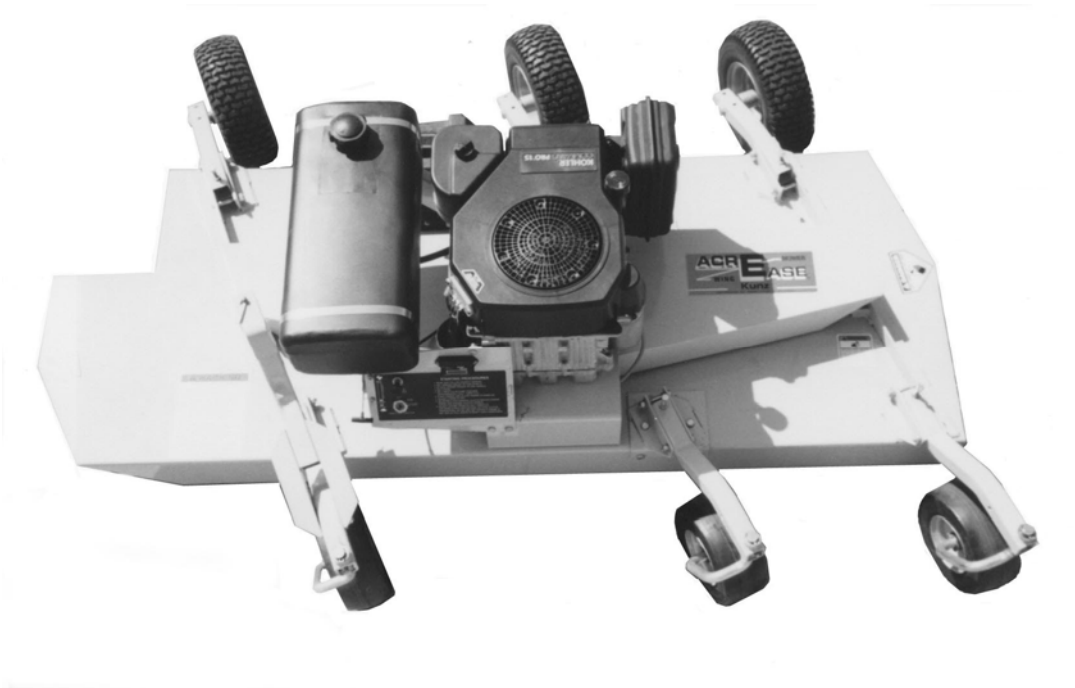

The front and rear are sold separately.
Rear Floatation Kit (Part # 003902)
Front Floatation Kit (Part # 003904)

