

ACREASE

57" ROUGH CUT



OWNER'S MANUAL

With Assembly Instructions

For Model: MR55H

KUNZ ENGINEERING, INC. / MENDOTA, IL 61342 / PH (815) 539-6954



ASSEMBLY INSTRUCTIONS

Read the complete assembly instructions before starting the assembly.

You should have:

- one mower deck assembly
- two carrier arm assemblies
- two rear tire assemblies
- one ATV tongue assembly

A. ASSEMBLY OF MOWER WHEELS

1. Set the mower deck assembly on wood blocks so that it is suspended off the ground.

Note: The operator controls are on the front of the deck. (Left and right are determined by looking in the direction of travel or by standing at the rear of the deck assembly looking forward.)

2. Install the rear tire assemblies on the carrier arm assemblies. Remove the hex nut and lock washer from the rear tire assembly and install the 5/8"x7-1/2" tire axle bolt through the hole in the carrier arm assembly. **See figure 1.** Secure assembly with the lock washer and hex nut provided on the rear tire assembly. The rear tires should be offset to the outside of the deck assembly on both sides. **See figure 2.**
3. Install the two carrier arm assemblies in the pivot arms, which are located on the mower deck assembly. Place the assembly so that the castered tires are on the front and the fixed tires are on the back. **See figure 2.** Secure with 1/2" x 3-1/2" hex head bolts and lock nuts provided on the pivot arms. Mount the height adjust screw on the deck assembly in the hole provided. Secure with the 1/2"x1" hex head bolt and lock nut provided on the height adjust screw.

Note: Tighten 1/2" x 3-1/2" and 1/2" x 1" hex head bolts until just snug. This area needs to pivot when adjusting the height. Under tightening can result in excessive wear and flexing. Over tightening will make adjusting the cutting height very difficult.

B. INSTALLATION OF TONGUE ASSEMBLY

1. The tongue can be installed either on the left or right caster assembly depending on how the tow-behind mower will be towed. **See figure 2.** Secure the hitch pivot on the chosen caster assembly with the 1/2" x 3-1/2" hex head bolt, lock washer, and nut provided.
2. Install the tongue into the hitch pivot and secure by placing the provided 5/16" wire lock pins on each side of the hitch pivot.

Note: To help prevent any unwanted pin removal caused by oncoming debris install the 5/16" wire lock pins with the wire lock section back from the direction of travel. **See Figure 3.**

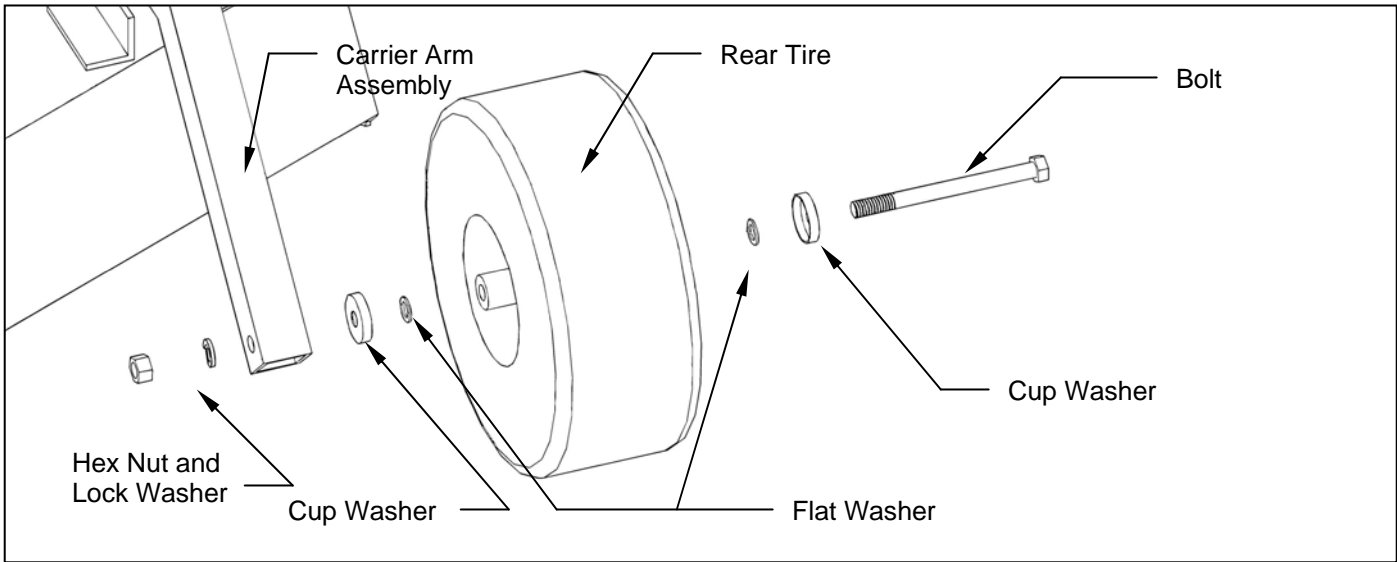

Figure 1: Rear Tire Assembly Installation

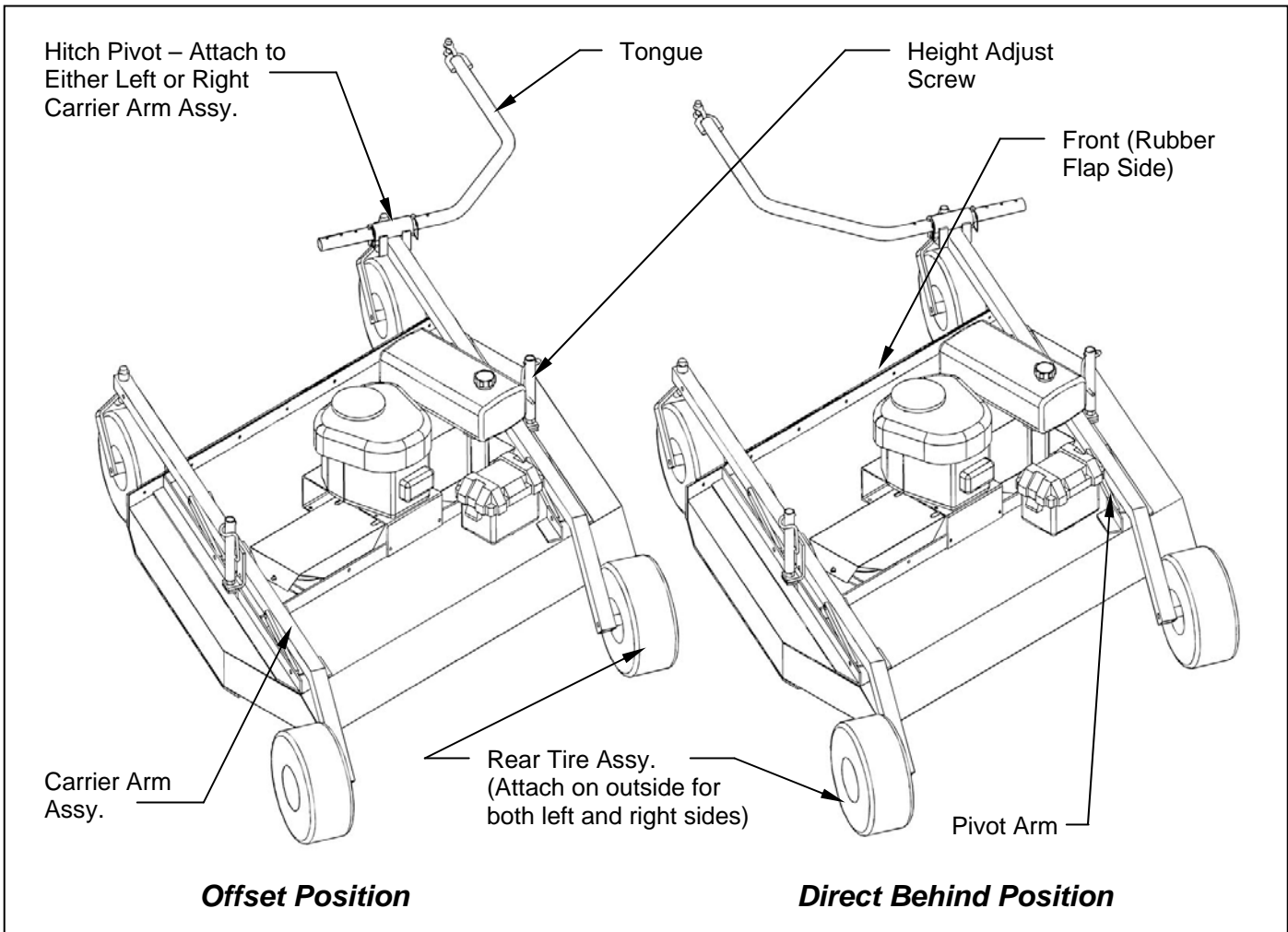

Figure 2: Assembly of Carrier Arm Assy., Hitch Pivot, and Tongue

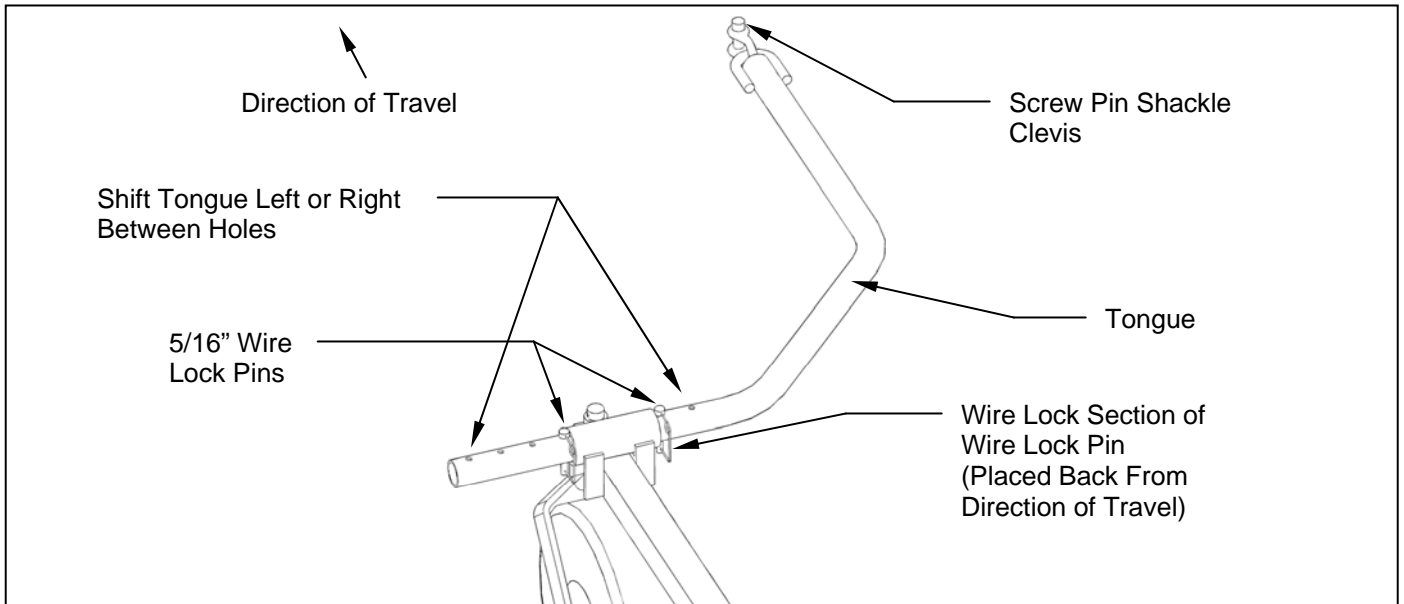

Figure 3: ATV Tongue Assembly

OPERATIONS AND ADJUSTMENTS



This safety alert symbol is used to indicate safety instructions. Follow these instructions to avoid personal injury and/or property damage. Read and follow all instructions in this manual and the attached engine manual.



Read all Owners Manuals before using equipment.



Know locations and functions of all controls before operating the mower.

A. TONGUE CONFIGURATIONS AND ADJUSTMENTS



Shut off the engine and allow the mower blades to come to a complete stop before adjusting the tongue.

The hitching system is designed so that the rough cut mower can be pulled directly behind a tow vehicle or offset to the left or right. **See Figure 4.**

Note: When pulling the mower directly behind, the hitch pivot should be fastened on the right carrier arm for maximum maneuverability. **See Figure 2.** When pulling the mower in the offset position the hitch pivot can be fastened on either the right or left carrier arm. **See Figure 2.**

The tongue is equipped with a screw pin shackle clevis to provide movement in all directions on rough uneven ground. To prevent loss of the screw pin due to vibration or debris, place the screw pin through the tow vehicle hitch and clevis and turn the screw pin until snug.

The tongue is designed to adjust from left to right within the hitch pivot. This allows the mowers position to be varied behind the tow vehicle. This is accomplished by pulling the 5/16" wire lock pins out and choosing two other hole locations on the tongue. **See Figure 3.**

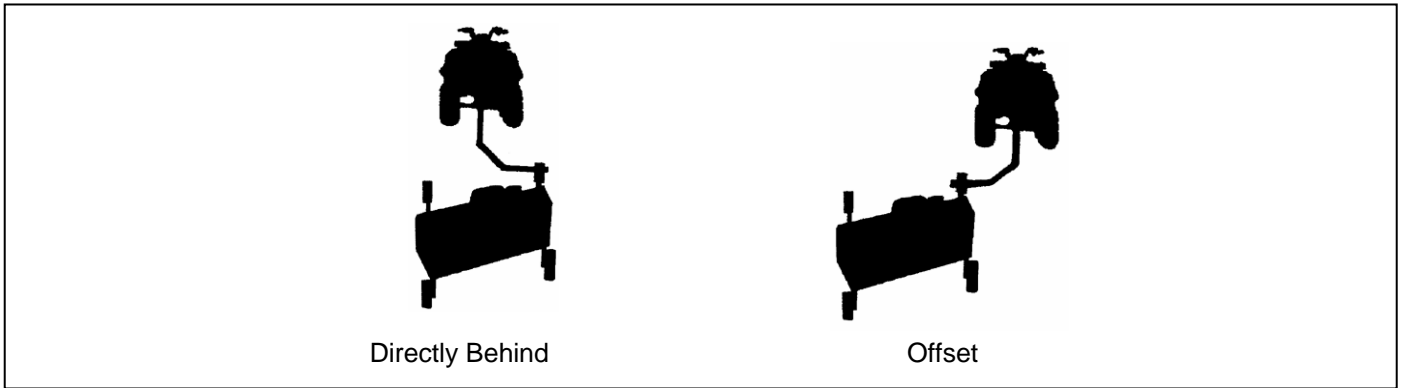

Figure 4: Rough Cut Tow Behind Towing Suggestions

B. ADJUSTING CUTTING HEIGHT



Shut off the engine and allow the mower blades to come to a complete stop before adjusting the cutting height.

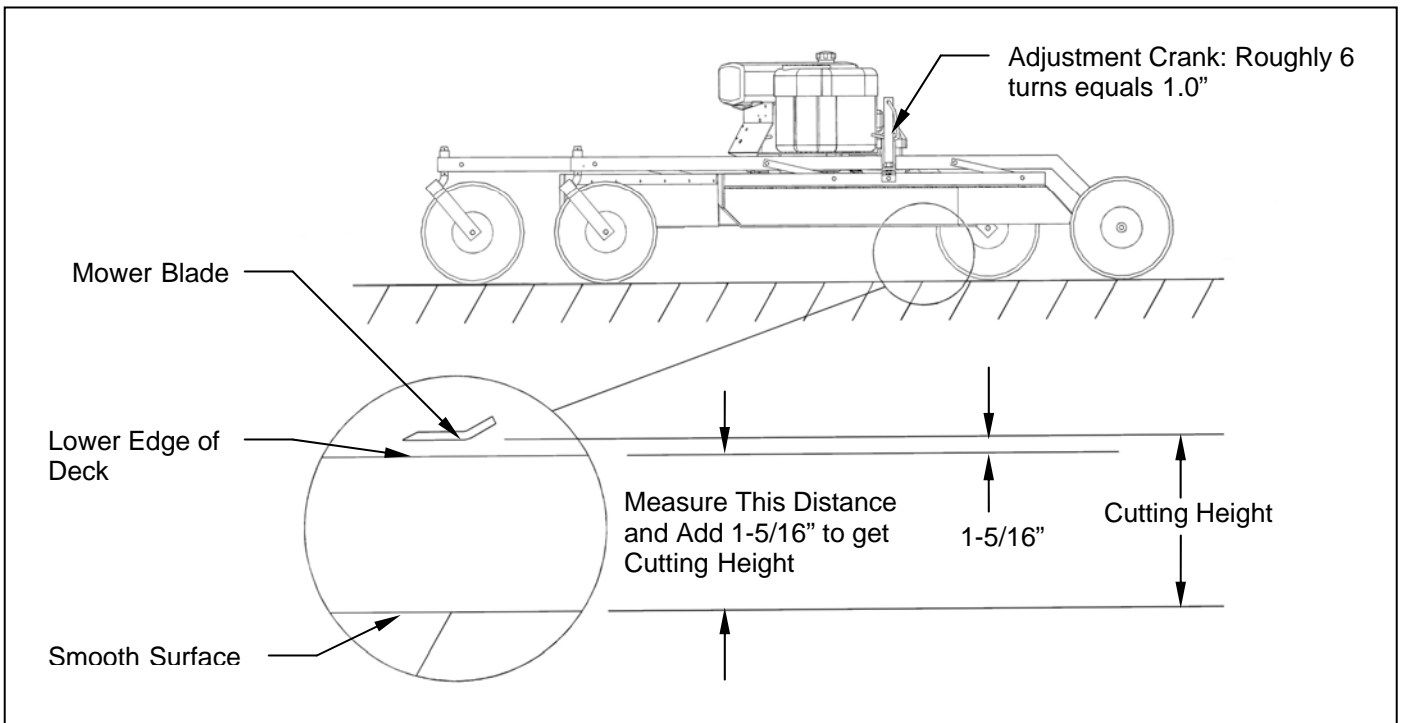

Figure 5: Adjusting Rough Cut Mower Cutting Height

The cutting height can be adjusted in a range from 2.0" to 8.0". This is accomplished by turning the height adjust cranks on both sides of the mower. **See Figure 5.** Turn the cranks clockwise to raise the mower cutting height and counter-clockwise to lower the mower cutting height.

Adjust the mower as follows:

1. Pull the mower on to a smooth, level surface.
2. Adjust the mower evenly from side to side by measuring to the ground from the lower edge of the mower deck. The desired height will be the distance from the ground to the outside lower edge of the mower deck plus 1-5/16". The mower blade cutting edge is 1-5/16" above the outside lower edge of the mower deck.

Note: If the height adjust cranks do not turn easily, the pivot bolts holding the carrier arm assemblies and height adjust screw may be too tight. Loosen the pivot bolts slightly to allow easier pivoting. Care should be taken not to loosen too much or excess wear and flexing may occur. Greasing the threads may also allow greater ease in adjustment.

Note: After leveling mower deck, quick field adjustment can be completed by counting crank turns. Roughly 6 turns will equal 1" of vertical movement.

The adjustment crank may unturn due to vibration. This will allow the mower's cutting height to change. The crank can be secured by folding it down between the adjustment nut tube and the upper pivot support. **See Figure 6.**

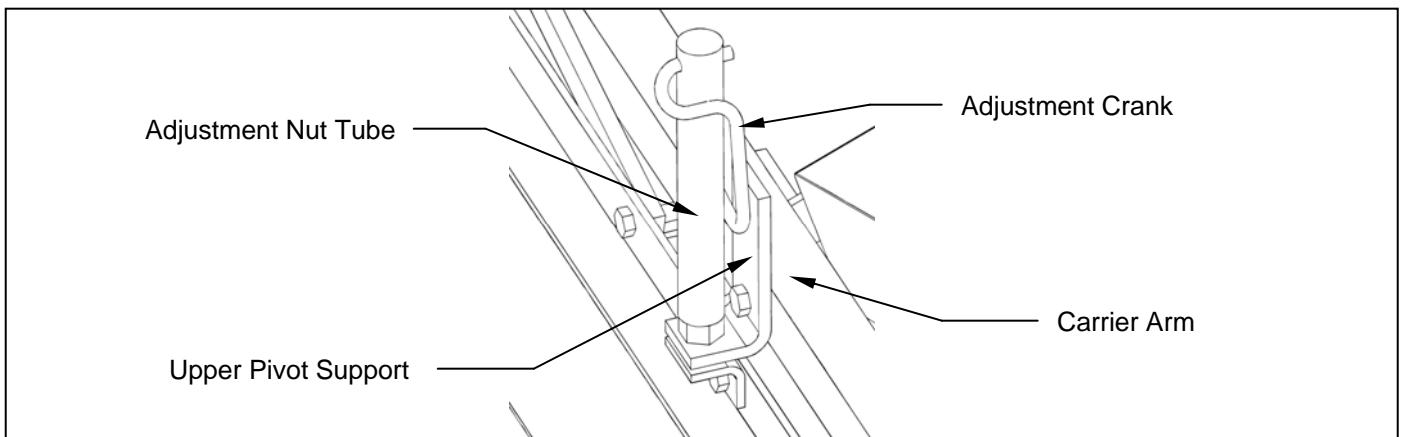

Figure 6: Securing Crank While Not In Use

C. STARTING ENGINE



Set Parking Brake on tow vehicle.

Attach mower tongue to tow vehicle.



Do not start rough cut mower unless it is attached to the tow vehicle.

Set the choke to the desired position.

Set the throttle at approximately half throttle.

Start engine and allow engine to warm up.

Set engine speed at about half throttle and engage mower blades clutch handle. (The clutch handle is located at the front of the mower under the engine.)

Note: Some belt squealing may occur on engagement. This is normal for a manual clutch engagement design.



If the mower's engine dies while in use, remove the rough cut mower from the uncut area before attempting to engage the clutch. Inspect the blades for any obstructions that may prevent blade engagement. Failure to follow these instructions may result in premature belt failure or a fire.

Adjust engine speed to full throttle.

D. SHUTTING OFF WING MOWER



Shift to neutral and set the parking brake before dismounting the tow vehicle.

Slow the engine speed down and disengage the clutch handle.

Allow engine to cool down for a short time before moving the ignition switch to the **off** position.

E. MOWER OPERATION



Clean or replace any safety signs that are not readable or damaged.



Remove all objects from the work area that might be picked up and thrown by the blades.



Do not mow when children and others are around.



Do not fill fuel tank while engine is running or hot.



Keep all safety shields and deflectors in place during operation.



Remove grass build up from under safety shields before each use. Do not remove safety shields while engine is running. Dry grass build up around belts and sheaves can cause fires.



Shut off engine before disconnecting the mower from the tow vehicle or attempting to move the mower by hand.



Never carry children or passengers.



Do not allow children to operate this machine.



Slow down and watch the ends of the mower when making turns so objects are not struck and/or run over.



Look down, to the sides, and behind before and while backing to avoid backing over something or someone. Care should also be taken while backing so that the mower does not jackknife and damage hitches.



Stop the mower blades on the mower if the tow vehicle becomes stuck or stops going forward because of loss of traction. Shut off the engine on the mower before attempting to push or pull the tow vehicle.

Listen to the rough cut mower engine while mowing. The engine should run free and not work too hard. Working the engine too hard will cause overheating and premature failure.



If the mower's engine dies while in use, remove the rough cut mower from the uncut area before attempting to engage the clutch. Inspect the blades for any obstructions that may prevent blade engagement. Failure to follow these instructions may result in premature belt failure or a fire.

Do not allow material to build up on the air inlet to the engine cooling system. Special care should be taken to make sure the engine is getting enough inlet air. Do not allow the engine cooling fins under the shroud to be blocked. If air flow over the engine is restricted, the engine could overheat.

F. DRIVE BELT REMOVAL AND TENSION – Refer to Figure 7



Shut off engine and allow mower blades to stop turning before making any adjustments or repairs.

Remove the safety shields.

Loosen the nuts on the spring-loaded idler; adjust bolt until the belt can be slipped off the idler and drive sheaves.

Slip the belt down under the drive sheave and off the blade spindle sheaves.

Install the new belt and then adjust the tension as follows: **See Figure 7.** Take special care to make sure that the belt is placed between the brake stud and the idler pulley.

With the clutch engaged, adjust the nuts on the spring-loaded idler adjuster bolt until the length of the spring is between 2" and 2-1/8". This is the initial belt break in spring length. When the belt is broken in after several hours of mowing, the running spring length should be between 2-1/4" and 2-3/8". For maximum belt life, periodic checks every 3-4 hours should be done to make sure the spring length has not exceeded the recommended running length.

Note: Failure to periodically adjust the belt tension will result in severe belt wear and premature belt failure.

This model comes with a belt brake, which is a safety feature that stops the blades from turning after the clutch is disengaged. The only time the brake should be in contact with the belt is when the clutch is disengaged.

⚠ The brake stud must be adjusted. If the brake stud is not adjusted correctly, the blades will still spin even though the clutch may be in the disengaged position. Always shut mower engine off before servicing.

To adjust the brake, place the clutch in the engaged position. Loosen the bolt on the top of the brake stud. Slide the brake stud in the slot until there is about 5/8" of clearance between the belt and the brake stud. Tighten the bolt at the top of the brake stud. To ensure that the brake works properly the spring length must be set correctly. With the clutch disengaged make sure the spring length is no more than 2-3/4". After the belt breaks in the clearance between the belt and the brake stud should be around 1/2". To prevent over-braking the brake clearance should be checked every 3-4 hours.

⚠ If brake stud is not set in correct position, under-braking or over-braking may occur. If over-braking occurs, premature belt failure or a possible fire could occur due to excessive friction and overheating.

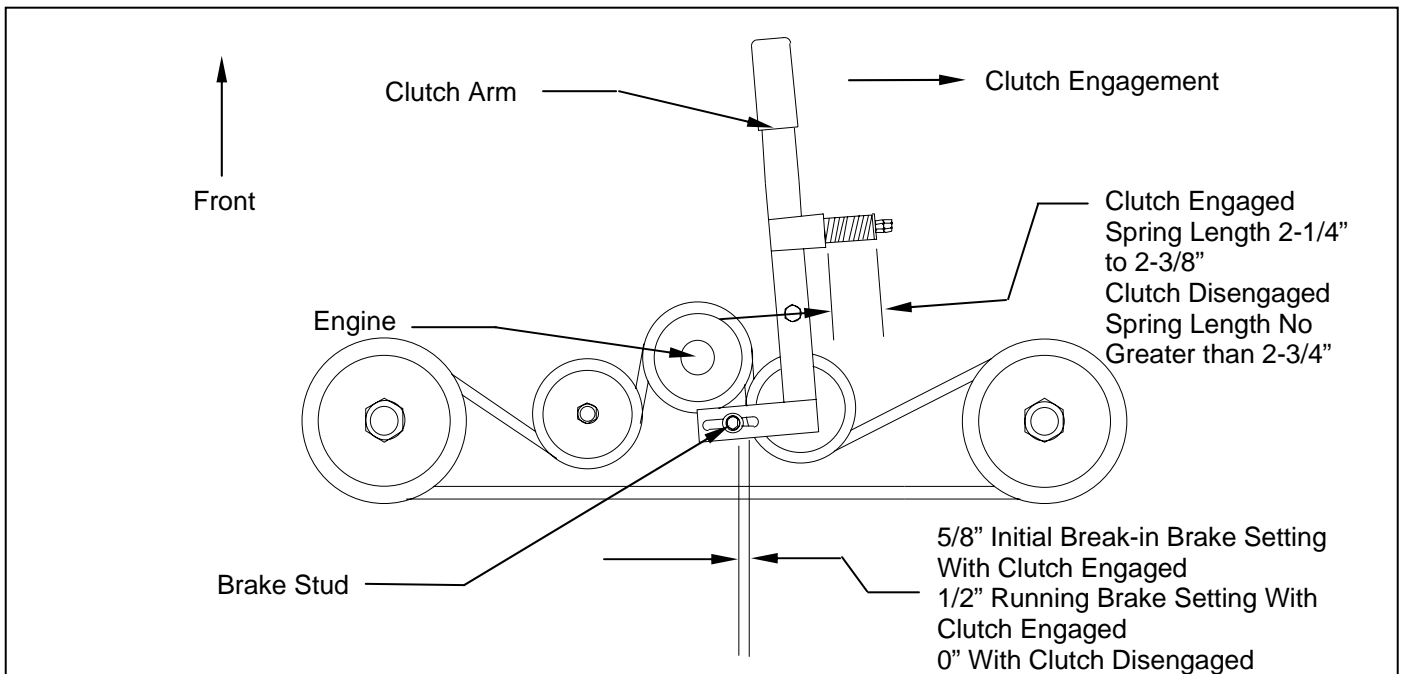

Figure 7: Belt Pattern, Spring Adjustment, and Brake Adjustment

G. MOWER BLADE REMOVAL, BALANCING & INSTALLATION



Sharp blades can cause bodily injury if not handled properly.

When removing the blade, it is recommended that a block of wood be placed between the blade and the underside of the mower deck. This will allow the removal of the blade without the need to hold the blade by hand.



Always balance the mower blades each time they are sharpened.

Out of balance mower blades cause excess vibrations which lead to premature bearing failures, bolts coming loose, and overall deterioration of the wing mowers.



Always properly tighten the blade bolts to the specified torque. Failure to do so can lead to unwanted loosening of the blade and damage to the blade holding saddle.

The Model MR55H uses the Kunz Engineering Part # (202141) blade bolt. This particular hex head bolt is a 3/4" – 16NF x 1-1/4" long, grade 5 and it's proper torque is 300 ft-lbs.

To ease in the blade installation process, use the same block of wood and method used during the removal of the blades.

H. LUBRICATION

There are five lubrication points on the rough cut mower -- one spring-loaded idler pivot, two caster wheel pivots, and two blade spindles. Lubricate at approximately 10 hr. intervals or more often as required in dusty conditions. Lubricate the blade spindles 2-5 pumps every 50 hours. (The bearings have trash guard seals to hold the seals in place during lubrication.) Lubricate with a high grade of pressure gun grease.

Note: Do not over grease blade spindles. Blade spindles are initially greased at the factory. Greasing before 50 hrs. may cause bearing seal damage which will result in premature bearing failure.

I. STORAGE

If the mower is stored outside, the engine should be covered to prevent water from getting inside the engine during heavy rainstorms. See the Engine Manual for additional information.

ACREASE ROUGH CUT MOWER SPECIFICATIONS

Model
MR55H

ENGINE:

Engine Make	Honda
Engine Model	GXV610
Cylinders	2
Cycles	4
Crankshaft	Vertical
Engine HP	18
Bore	3.03"
Stroke	2.60"
Displacement	37.5 cubic inches
Oil Capacity	2.3 U.S. qt (with oil filter change)
Crankshaft Dia.	1.0"
Key Slot	1/4"
Crankshaft Length	3.11"
Threaded Hole in End of Crankshaft	7/16-20
Engine Mounting Bolts	3/8-16x1.50 Through Bolt
Starter	Electric
Choke	Manual

MOWER:

Fuel Tank	3-3/4 Gal.
Effective Cutting Width	57"
Deck Construction	10 ga. Welded steel
Cutting Height	2" to 8"
Height Adjustment	2 Cranks
Rear Wheels (Fixed) (2 ply Turf Pnuematic)	Two 15/600 x 6
Front Wheels (Caster) (2 ply Turf Pnuematic)	Two 5.30/4.50 x 6
Blade Dia.	2-30"
Engine Speed, Blades Running	3600 RPM

CLUTCH TYPE

Engagement Speed	Manual
------------------	--------

DIMENSIONS

Length	98"
Width	60"
Height	29"
Weight	520 lbs.

HITCH

Hitch Type	ATV Tongue
------------	------------

TOUCH-UP PAINT COLOR

Pewter Gray, Krylon #1606

ACREASE ROUGH CUT MOWER PARTS MODEL MR55H

<u>Item</u>	<u>Part #</u>	<u>Description</u>	<u>Quantity</u>
1	214021	Cup Washer	8
2	216002	Wire Lock Pin, .31" x 2.50"	2
3	216009	Screw Pin Shackle Clevis	1
4	222005	Worm Drive Hose Clamp (7-7/8" to 9-1/8" Clamping Dia.)	2
5	225003	Compression Spring, 3"L x 1-3/32" O.D. x .135" Wire dia.	1
6	226003	Offset Wheel Assy. (15/600 x 6, 2 Ply Turf)	2
7	226004	Centered Wheel Assy. (5.30/4.50 x 6, 2 Ply Stud)	2
8	238004	"V" Belt, .62" x 95.9" O.C.	1
9	241001	Flat Idler, 4" O.D. x 3/8" Hole	1
10	241009	Flat Idler (Steel), 4" O.D. x 1/2" Hole	1
11	241010	"V" Sheave, 5" Dia. 1" Bore	1
12	258015	Spindle Assy.	2
	900075	Spindle Shaft (1)	
	600159	Sheave Spacer (1.98" Long) (1)	
	900078	Housing Assy. (With Two Bearings) (1)	
	243006	Bearing (6206 w/ Trash Guard Seals) (2)	
	600158	Bearing Spacer (1.41" Long) (1)	
	241008	Sheave, (7-1/2" Dia., B-Section) (1)	
13	259002	Offset Mower Blade, 2-1/2" Wide, 30" Long, 3/4" Hole	2
14	264001	Ignition Switch	1
15	264003	Hour/Tack Meter	1
16	269007	Choke Control, 22.5"	1
17	269009	Throttle Control, 27"	1
18	275001	Control Panel Decal, Starting Instructions	1
18	275002	Warning Decal General	1
18	275003	Danger Decal, Cut Finger	2
18	275007	Warning Decal, Belt Sheild	2
18	275010	Name Decal, 57" Rough Cut	1
18	275011	Clutch Engagement Decal	1
18	275017	Name Decal, AcrEase	1
19	277002	Rubber Gromet	6
20	277010	Fuel Tank, 3.75 Gal. (Plastic)(Use Gas Cap 277013)	1
21	277011	Handle Grip	1
22	277013	Gas Cap (For Fuel Tank 277010)	1
23	600071	Spacer, 1.38" O.D. x 1.33" Wall x 2.19"	1
24	600126	Flap Retainer Strip	1
25	600133	Belt Sheild	2
26	600136	Brake Stud	1
27	600142	Upper Pivot Support	2
28	600143	Safety Belting	1
29	600146	Crank Arm	2
30	600189	Idler Spacer Block	1
31	900023	Control Panel	1

<u>Item</u>	<u>Part #</u>	<u>Description</u>	<u>Quantity</u>
32	900049	Battery Box Assy.	1
33	900058	Hitch Pivot	1
34	900061	Pivot Arm	4
35	900062	Height Adjust Nut	2
36	900063	Clutch Arm	1
37	900065	Idler Arm Assy.	1
	243005	Bronze Bearing, 1/2" I.D. x 3/4" O.D. x .75" Long	2
38	900066	Screw Adjuster	2
39	900069	Mower Deck	1
40	600172	Engine Support Bracket	1
41	900073	Caster Fork	2
42	900079	Tank Support	1
43	900082	Tongue	1
44	900106	Carrier Arm	2
	243010	Plastic Bearing, 1-3/8" O.D. x 1.00" I.D.	4

MODEL MR55H

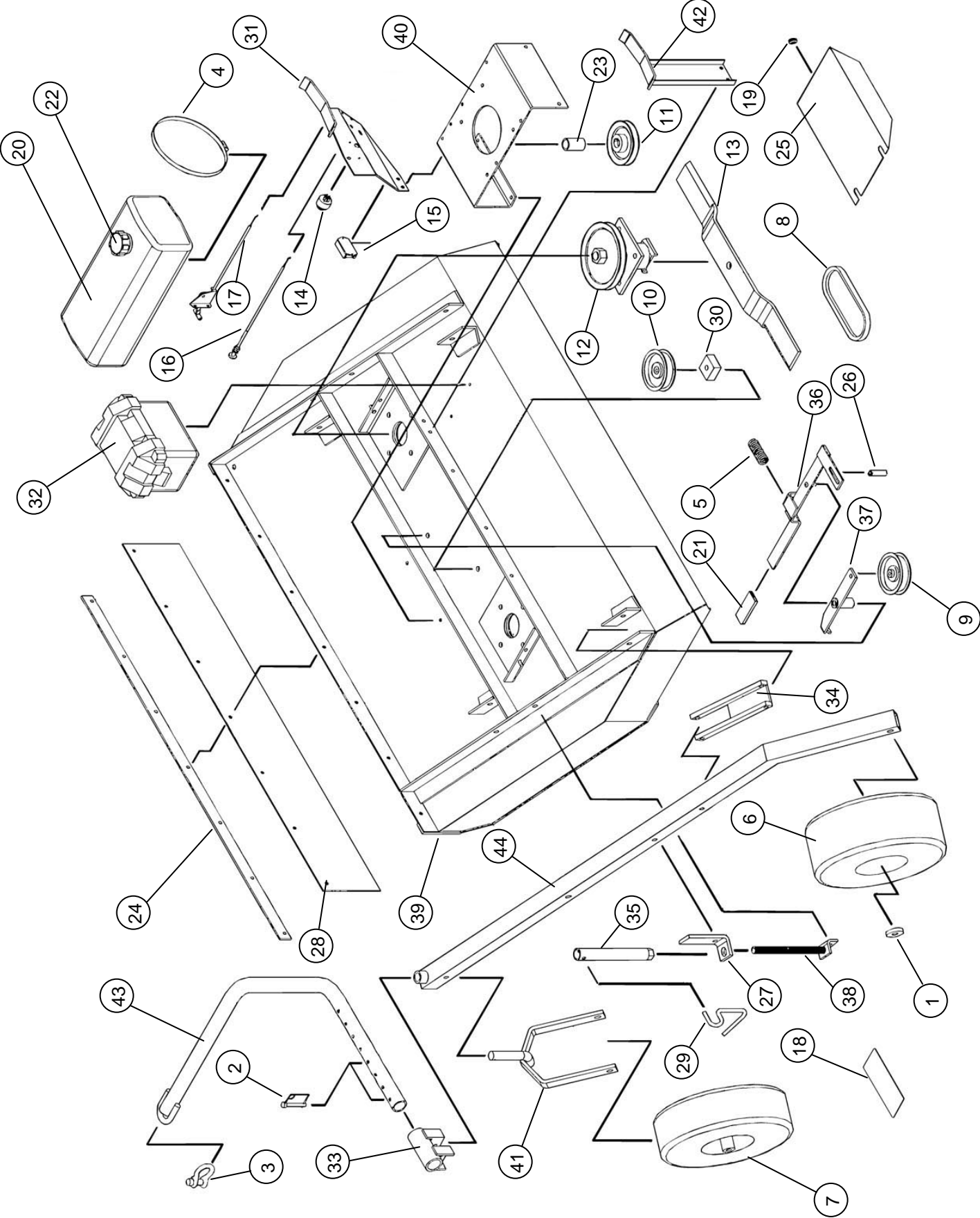

SAFETY SIGNS AND LOCATIONS

WARNING

AVOID INJURY OR DEATH

- Read and follow owner's manual.
- Know location and function of all controls.
- Before starting engine, remove grass build-up from under safety shields.
- Before starting engine, attach machine to tow vehicle.
- Shut off engine before disconnecting machine from tow vehicle or attempting to move machine by hand.
- Do not fill fuel tank while engine is running or hot.
- If tow vehicle stops going forward, stop engine on towed mower before trying to push or pull tow vehicle.
- When making turns, slow down and watch ends of towed mower.
- Never carry children or passengers.
- Look down, to the sides, and behind before and while backing.
- Do not allow children to operate this machine.
- Do not mow when children and others are around.
- Remove all objects that may be thrown by blade.
- Keep safety shields and deflectors in place.
- Shut off engine while in transport.
- Before dismounting tow vehicle: shift to neutral, disengage power to tow vehicle mower, and set parking brake.
- Be sure blades, engine and moving parts are stopped before placing hands or feet near blade or performing service.

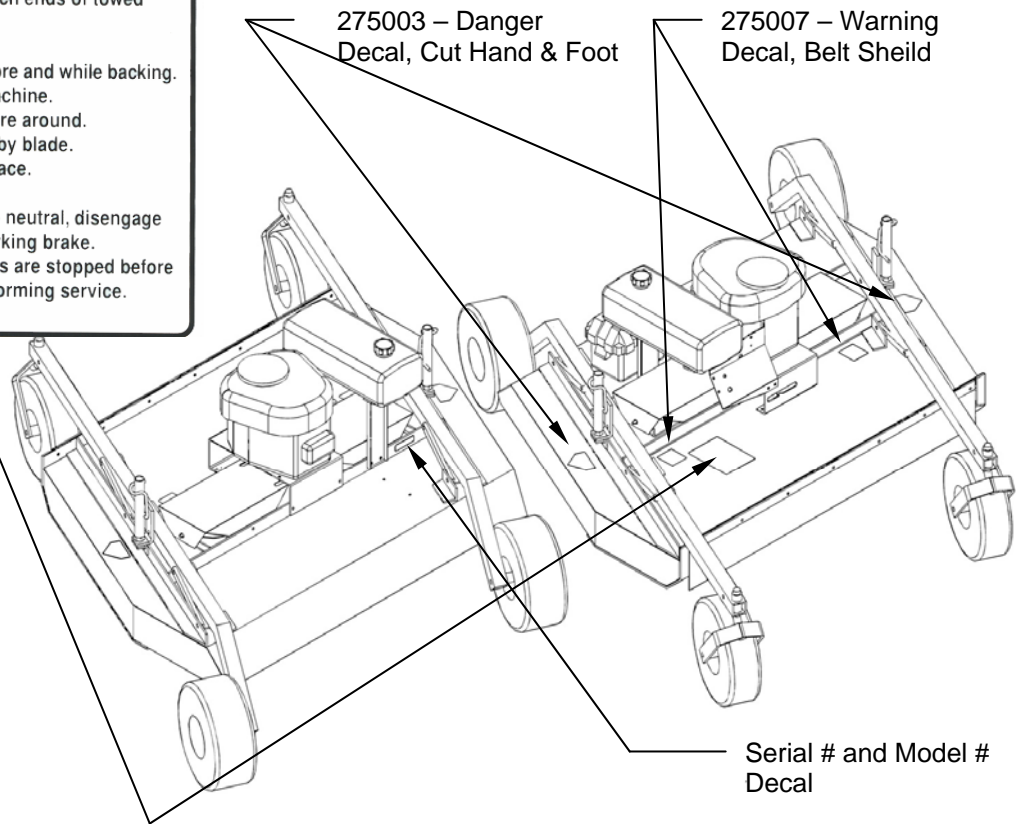

Clean or Replace Any Safety Signs That Are not Readable or Damaged

Replacement decals can be purchased from your local dealer or

Kunz Engineering Inc.
Mendota, IL 61342
(815) 539-6954

OPTIONAL EQUIPMENT

A. OPTIONAL WETLANDS KIT

The optional wetlands kit features an extra set of tires for added ground support in soft or water saturated areas. The following are applications and features that the wetlands kit works best in.

- Great for wetlands or marshy areas that stay wet all year around.
- Works well in combination with small personal amphibious vehicles or tracked ATVs.
- More than doubles the tire surface area in contact with the ground.
- Very easy to install bolt-on kit.
- Works on all existing and new rough cut mowers.
- The rough cut mower **will not** float with the wetlands kit installed. Water greater than 2-3" in depth should be avoided.



Wetlands Kit (Part # 003905)

